



2026

**Guidance for OSV
(Offshore Support Vessels)**

APPLICATION OF "Guidance for OSV (Offshore Support Vessels)"

1. Unless expressly provided otherwise, the requirements in the Guidance apply to Offshore Support Vessels(OSV) for which contracts for construction are signed on or after 1 July 2026.
2. The amendments to the Rules for 2024 edition and their effective date are as follows;

Effective Date 1 January 2026 (The application date for survey, Related Circular No. : 2025-14-E)

CHAPTER 5 ANCHOR HANDLING AND TOWING VESSELS

- Section 5 Anchor Handling/Towing Winch and Accessories**
- 501. ~ 508. has been amended.

Effective Date 1 March 2026 (Related Circular No. : 2026-1-E)

CHAPTER 1 GENERAL

- Section 1 General**
- 101. 5. has been newly added.
- Section 2 Definition**
- 202. (7), (8) has been newly added.
- 203. has been newly added.

CHAPTER 2 CLASSIFICATION AND SURVEYS

- Section 2 Classification**
- 202. 1. has been amended.

CHAPTER 3 STRUCTURES AND EQUIPMENT

- Section 1 Stability**
- 102. has been deleted.

CHAPTER 5 ANCHOR HANDLING AND TOWING VESSELS

Section 2 Stability

- 201. 1. has been amended.

CHAPTER 6 HEAVY LIFT VESSELS

Section 2 Stability

- 201. 1. has been amended.
- 202. and 203. has been deleted.

CHAPTER 10 CABLE LAYING VESSEL

- This chapter has been newly added.

CHAPTER 11 CREW TRANSFER VESSEL

- This chapter has been newly added.

Annex 1 SHIPS CARRYING INDUSTRIAL PERSONNEL (IP)

- This annex has been newly added.

CONTENTS

CHAPTER 1 GENERAL	1
Section 1 General	1
Section 2 Definition	2
CHAPTER 2 CLASSIFICATION AND SURVEYS	3
Section 1 General	3
Section 2 Classification	3
Section 3 Surveys	7
CHAPTER 3 STRUCTURES AND EQUIPMENT	9
Section 1 Stability	9
Section 2 Hull Structures	9
Section 3 Hull Equipment	10
Section 4 Machinery	11
Section 5 Electrical Installations	11
Section 6 Fire Protection and Fire Extinguishing Systems	12
CHAPTER 4 OFFSHORE SUPPLY VESSELS	13
Section 1 General	13
Section 2 Hull Structures	14
Section 3 Cargo Piping Systems	15
Section 4 Machinery	16
CHAPTER 5 ANCHOR HANDLING AND TOWING VESSELS	17
Section 1 General	17
Section 2 Stability	18
Section 3 Hull Structures	18
Section 4 Hull Equipment	20
Section 5 Anchor Handling/Towing Winch and Accessories	20
Section 6 Machinery	22
Section 7 Fire Protection and Fire Extinguishing Systems	23
CHAPTER 6 HEAVY LIFT VESSELS	25
Section 1 General	25
Section 2 Stability	25
Section 3 Hull Structures	26
Section 4 Hull Equipment	26
Section 5 Machinery	27
Section 6 Positioning System	28

CHAPTER 7 WIND TURBINE INSTALLATION VESSELS	29
Section 1 General	29
Section 2 Stability	29
Section 3 Hull Structures	29
Section 4 Hull Equipment	29
Section 5 Machinery	30
Section 6 Positioning Systems	30
CHAPTER 8 FIRE FIGHTING VESSELS	31
Section 1 General	31
Section 2 Stability	32
Section 3 Hull Structures	33
Section 4 Fire fighting equipment for other vessels	33
Section 5 Machinery	38
Section 6 Fire Protection and Fire Extinguishing Systems	38
Section 7 Positioning Systems	39
CHAPTER 9 OIL SPILL RECOVERY VESSELS	41
Section 1 General	41
Section 2 Definitions	42
Section 3 Hull Structures	43
Section 4 Hull Equipment	43
Section 5 Tank Arrangement	43
Section 6 Machinery and Electrical Installations in Hazardous Areas	44
Section 7 Fire Protection and Fire Extinguishing Systems	46
CHAPTER 10 CABLE LAYING VESSEL	49
Section 1 General	49
Section 2 Stability	49
Section 3 Hull Structures	49
Section 4 Hull Equipment	50
Section 5 Machinery	50
Section 6 Positioning System	52
Section 7 Fire Protection and Fire Fighting	52
CHAPTER 11 CREW TRANSFER VESSEL	53
Section 1 General	53
Section 2 Stability	53
Section 3 Hull Structures	53
Section 4 Hull Equipment	53
Section 5 Safe Transfer of Personnel	53
Annex 1 SHIPS CARRYING INDUSTRIAL PERSONNEL (IP)	55

CHAPTER 1 GENERAL

Section 1 General

101. Application

1. Requirements stipulated in this Guidance apply to the Offshore Support Vessels (hereinafter referred to as vessels in this Guidance) defined in **202**.
2. Unless otherwise specified in this Guidance, relevant requirements of **Rules for the Classification of Steel Ships** are to be applied.
3. The hull structures, equipment and scantlings of ships, to be classified for restricted service, may be appropriately modified according to the conditions of service.
4. The Society may request additional requirements, depending upon utility and designated operations.
5. The cargo ships and high-speed cargo craft of 500 gross tonnage and above engaged on international voyages that carry more than 12 industrial personnel (IP) are required to comply with **Annex 1** in addition to this guidance. (2026)
 - (1) Wherever in this guidance, or in the IP Code, the number of industrial personnel appears as a parameter, it shall be the aggregate number of industrial personnel(IP), special personnel(SP) and passengers carried on board, where the number of passengers shall not exceed 12.

102. Ships of unusual form or proportion, or intended for carriage of special cargoes

In ships of unusual form or proportion, or intended for carriage of special cargoes, when deemed necessary, the requirements concerning hull structures, equipment, arrangement and scantlings will be decided for such ships based on the general principle of this Guidance.

103. Equivalency

Even though the hull structures, equipment, arrangement, scantlings and machinery(including electrical installations) are in compliance with this Guidance, it will be accepted as meeting this guidance provided that the Society is satisfied that such structures, equipment, arrangement, scantlings and machinery are equivalent to those required in this Guidance.

104. Direct strength calculation

1. Where approved by the Society, scantlings of structural members may be determined based on direct strength calculation. Where the calculated scantlings based on direct strength calculation exceed the scantlings required in this Guidance, the former is to be adopted.
2. Where the direct strength calculation specified in the preceding **Par 1** is carried out, the results and the necessary data for the calculation are to be submitted to the Society

105. Novel Features

Offshore Support Vessels, machinery and systems which contain novel features of design to which the provisions of these Guidance are not directly applicable may be classed on the basis that these Guidance, insofar as applicable, has been complied with and that special consideration has been given to the novel features, based on the best information available at that time. Risk evaluations for the justification of alternative arrangements or novel features may be applicable either to the offshore support vessel as a whole, or to individual systems, subsystems, equipment or components.

Section 2 Definition

201. Application

The definitions of the terms and symbols which appear in this Guidance are as specified in this Section, in addition to those specified elsewhere.

202. Offshore support vessel

“Offshore Support Vessel” is a self-propelled vessel whose regular trade is to provide services in support of exploration, exploitation, or production of offshore energy or alternative energy resources. These services may include but are not limited to: transportation of supplies and equipment, towing and anchoring of offshore structures, fire fighting, handling heavy surface and subsea loads, oil spill recovery and wind turbine installation. OSV is defined according to their purpose as follows:

- (1) **Offshore supply vessel** is specified in **Ch 4, 101. 1.**
- (2) **Anchor handling and towing vessel** is specified in **Ch 5, 101. 1.**
- (3) **Heavy lift vessel** is specified in **Ch 6, 101. 1.**
- (4) **Wind turbine installation vessel** is specified in **Ch 7, 101. 1.**
- (5) **Fire fighting vessel** is specified in **Ch 8, 101.**
- (6) **Oil recovery vessel** is specified in **Ch 9, 101. 1.**
- (7) **Cable laying vessel** is specified in **Ch 10, 101. 1. (2026)**
- (8) **Crew transfer vessel** is specified in **Ch 11, 101. 1. (2026)**

203. Definition of terms (2026)

1. A passenger is every person other than:

- (1) the master and the members of the crew or other persons employed or engaged in any capacity on board a ship on the business of that ship and
- (2) a child under one year of age.
- (3) Industrial personnel (IP)
- (4) Special personnel (SP)

2. **Industrial personnel (IP)** means all persons transported or accommodated on board for the purpose of offshore industrial activities performed on board other ships and/or offshore facilities.

3. **Special personnel(SP)** means all persons who are not passengers or members of the crew or children of under one year of age and who are carried on board in connection with the special purpose of that ship or because of special work being carried out aboard that ship.

4. **IP Code** means the International Code of Safety for Ships Carrying Industrial personnel, as adopted by the Maritime Safety Committee by resolution MSC.527(106), as may be amended.

5. **Offshore industrial activities** mean the construction, maintenance, decommissioning, operation or servicing of offshore facilities related, but not limited, to exploration and exploitation of resources by the renewable or hydrocarbon energy sectors, aquaculture, ocean mining or similar activities.

6. **Carriage** means transportation, accommodation or both.

7. **HSC Code** means the International Code of Safety for High-Speed Craft, 2000, as adopted by the Maritime Safety Committee of the Organization by resolution MSC.97(73), as amended.

8. **IP area** is every area or space where IP are normally intended to stay during voyage or are allowed to access.

9. **Personnel transfer** means the full sequence of the operation of transferring personnel and their equipment at sea to or from a ship to which this Code applies and from or to another ship or an offshore facility

10. **Essential systems** mean systems referred to in **SOLAS regulation II-2/21.4.** ⚓

CHAPTER 2 CLASSIFICATION AND SURVEYS

Section 1 General

101. General

1. The classification and surveys of Offshore Support Vessels intended to be classed or have been classed with the Society are to be in accordance with the requirements specified in this Chapter.
2. In the case of items not specified in this Chapter, the requirements specified in **Pt 1 of Rules for the Classification of Steel Ships** are to be applied.

Section 2 Classification

201. Classification

Offshore Support Vessels built and surveyed for the classification in accordance with this Guidance or in accordance with requirements deemed to be equivalent to this Guidance by the Society will be assigned a class and registered in the Register of Ships.

202. Class notations

1. The class will be distinguished by the class notations and the class notations assigned to the Offshore Support Vessels classed with the Society are to be in accordance with the requirements specified in **Pt 1, Ch 1, 201. of Rules for the Classification of Steel Ships**. However, Offshore Support Vessel shall be assigned as a ship type notation and the Special Feature Notation shall be assigned as followings.
 - (1) Special Feature Notation may be assigned as the following according to the specialized functional service of the Offshore Support Vessel.
 - (A) for supply service : Supply
 - (B) for anchor handling service : AH
 - (C) for towing service : Tow
 - (D) for heavy lift service : HL
 - (E) for wind turbine installation, maintenance and repair service : WTIMR
 - (F) for fire fighting service :
 - (a) FFS1, FFS2 or FFS3 according to the minimum requirement of **table 8.1**
 - (b) Satisfy the requirements for **FFS1 at the same time, satisfying the requirements for Offshore Support Vessel (FFS2) or Offshore Support Vessel (FFS3)** also , the Class notation **Offshore Support Vessel – FFS1 FFS2, or Offshore Support Vessel – FFS1 FFS3** may be assigned.
 - (c) Vessels not in full compliance with this **Ch 8** or not specifically built for the service intended to be covered by this **Ch 8**, but equipped with some fire fighting capability in accordance with this **Ch 8** may be assigned Special Feature Notation **FF**.
 - (G) for oil spill recovery service : Oil Spill Recovery
 - (H) for Submarine cable laying, maintenance and repair service : Cable layer (2026)
 - (I) for Personnel transfer : CTV (2026)
 - (J) for other services : Special Feature Notation considered appropriate by the Society
2. The combination of Special Feature Notation may be assigned corresponding to the specialized functional services of the Offshore Support Vessel. For example, an Offshore Support Vessel for anchor handling service and towing service may be assigned the class notation "Offshore Support Vessel – AH, Tow".
3. Offshore Support Vessels built with strengthened for carrying heavy cargoes specified in accordance with **Ch 3, 202.** may be assigned the relevant Special Feature Notation HDC(P, Locations) or HLC(ρ , Tanks) additionally.
 - (1) For example, an Offshore Support Vessel for anchor handling service, supply service and towing service, strengthened for heavy deck cargo of 30 kN/m² at main deck may be assigned the

class notation

Offshore Support Vessel – Supply AH Tow HDC(30 kN/m², main deck).

- (2) For example, an Offshore Support Vessel for anchor handling service, supply service and towing service, strengthened for heavy liquid cargo of specific gravity 2.5 in number 3 and 5 cargo tanks may be assigned the class notation

Offshore Support Vessel – Supply AH Tow HLC(2.5 SG, Tank Nos. 3 and 5).

203. Maintenance of classification

1. Offshore Support Vessels classed with the Society are to be subjected to the surveys to maintain the classification and are to be maintained in good condition in accordance with the requirements specified in this Chapter.
2. Plans and particulars of any proposed alterations to the scantlings or arrangements of hull, machinery or equipment that are approved by the Society are to be submitted for approval to the Society before the work is commenced and such alterations are to be surveyed by the Surveyor of the Society.

204. Classification survey during construction

1. General

At the Classification Survey during Construction, the hull, machinery and equipment are to be examined in detail in order to ascertain that they meet the relevant requirements of this Guidance.

2. Submission of plans and documents

- (1) At the Classification Survey during Construction, the following plans and documents are to be submitted to the Society for approval before the work is commenced.

(A) relating to Hull Structure

- (a) Midship section
- (b) Construction profile
- (c) Shell expansion
- (d) Watertight and oiltight bulkheads
- (e) Deck plans
- (f) Stem, sternframe and rudder
- (g) Single bottoms and double bottoms
- (h) Superstructure end bulkheads
- (i) Fore and aft bodies
- (j) Pillars and deck girders
- (k) Shaft tunnels
- (l) Foundations and the relevant structure plan of boilers, main engines, thrust and plummer blocks, generators, and other heavy weight auxiliary machinery.
- (m) Machinery casings
- (n) Deckhouses
- (o) Masts, derrick posts and derrick booms and the relevant structure plans
- (p) Final stability data
- (q) Loading manual
- (r) Where self elevating unit is installed, connection of all leg, bottom mats or spud can, structural plan of leg tanks, leg jack or other elevating unit and structure and control plan of jacking system etc.
- (s) Other plans and/or documents considered necessary by the Society

(B) relating to Machinery

- (a) Plans and data relevant to machinery installation specified in **Pt 5, Ch 1, Sec 2 of Rules for the Classification of Steel Ships.**
- (b) Electrical installations specified in **Pt 6, Ch 1 of Rules for the Classification of Steel Ships,** and automatic and remote control system specified in **Pt 6, Ch 2 of Rules for the Classification of Steel Ships.**
- (c) Fire extinguishing arrangements and inert gas system
- (d) Where dynamic positioning system is installed, structural plan, arrangement and control plan of dynamic positioning system
- (e) Other plans and/or documents considered necessary by the Society

- (2) At the Classification Survey during Construction, the following plans and documents are to be submitted to the Society for reference.
- (A) General arrangement
 - (B) Specification
 - (C) Calculation sheets for midship section modulus
 - (D) Where special cargoes are to be loaded on ships, the plans showing their distribution and loading arrangements.
 - (E) Calculation sheets for masts, derrick booms, boat davits, and similar structures requiring strength.
 - (F) Preliminary stability data.
 - (K) Where dynamic positioning system is installed, calculation sheet of dynamic positioning system, test procedures (test items, test procedures and criteria etc. for periodical survey)
 - (L) Where self elevating unit is installed, calculations substantiating adequacy of structure to transmit forces between legs and hull through the jacking systems, and calculations for capacity of resisting overturning moment.
 - (M) Other plans and/or documents considered necessary by the Society
- (3) Hydrostatic curves, capacity plans, records of sea trials and various test reports are to be submitted before the delivery of the ship.

3. Presence of surveyors

- (1) At the Classification Survey during Construction, the presence of the Surveyor is required at the following stages of the work in relation to hull and equipment.
- (A) When the tests of the materials specified in **Pt 2, Ch 1 of Rules for the Classification of Steel Ships** and the equipment specified in **Pt 4 of Rules for the Classification of Steel Ships** are carried out.
 - (B) When the tests of welding specified in **Pt 2, Ch 2 of Rules for the Classification of Steel Ships** are carried out.
 - (C) When designated by the Society during shop work or sub-assembly.
 - (D) When each block is assembled and erected.
 - (E) When each part of the hull is completed.
 - (F) When structural tests, leak test, hose tests and non-destructive tests are carried out.
 - (G) When performance tests are carried out on closing appliances of openings, remote control devices, steering gears, anchoring and mooring equipment, cargo handling appliances, fire detection and fire extinguishing systems, piping, etc.
 - (H) When each part of the fire protection construction is completed.
 - (I) When measurement of principal dimensions, hull deflection, etc. are carried out.
 - (J) When a loading instrument is installed on board.
 - (K) When the load line mark is marked.
 - (L) When the onboard tests and stability experiments are carried out.
 - (M) When deemed necessary by the Society.
- (2) At the Classification Survey during Construction, the presence of the Surveyor is required at the following stages of the work in relation to machinery.
- (A) When the tests of materials of main parts of machinery specified in **Pt 2 of Rules for the Classification of Steel Ships** are carried out.
 - (B) Main parts of machinery
 - (a) When the tests specified in either **Pt 5 or Pt 6 of Rules for the Classification of Steel Ships** according to the kind of machinery are carried out.
 - (b) When the materials are assembled for construction of the parts and the parts are assembled for installation on board.
 - (c) When machining of the main parts is finished and, if necessary, at appropriate stages during machining.
 - (d) In the case of welded construction, before welding is commenced and when it is completed.
 - (e) When the shop trials are carried out.
 - (C) When main parts of machinery are installed on board.
 - (D) When performance tests/onboard tests are carried out on measurement instruments, remote control devices of closing appliances, remote control devices for machinery and gears, automatic control devices, steering gear, mooring equipment, fire extinguishing equipments, piping, etc.
 - (E) When deemed necessary by the Society.

- (3) When performance tests are carried out on the installations for the specialized functional service of the Offshore Support Vessel.
- (4) For Offshore Support Vessels with a dynamic positioning system, when components of the dynamic positioning system are installed on the Offshore Support Vessels and tests are carried out in accordance with the testing procedure.

4. Tests

At the Classification Survey during Construction, hydrostatic tests, leak tests, hose tests and performance tests, etc are to be carried out in accordance with the relevant requirements of this Guidance.

5. Sea trials and stability experiments

- (1) For Classification Survey during Construction, the following tests are to be carried out if applicable in addition to the sea trials specified in **Pt 1, Ch 1, 308.** of **Rules for the Classification of Steel Ships.**
 - (A) For self-elevating Offshore Support Vessels, elevating and lowering tests of legs and decks and function tests of their safety devices; and where legs are not provided with bottom mats, pre-loading tests on each leg to a load as near as possible to that of the strength calculation for the leg.
 - (B) For Offshore Support Vessels with a dynamic positioning system, a function test of the dynamic positioning system.
- (2) Stability experiments

At the Classification Survey after Construction, stability experiments are to be carried out in accordance with the requirements specified in **Pt 1, Ch 1, 307.** of **Rules for the Classification of Steel Ships.**

205. Classification survey after construction

1. General

At the Classification Survey after Construction, the examination of the hull, machinery and equipment are carried out as required for the Special Survey corresponding to the age, kind and purpose of the Offshore Support Vessels and the actual scantlings, etc. of the main parts of Offshore Support Vessels are to be measured as necessary.

2. Submission of plans and documents

At the Classification Survey after Construction, plans and documents as may be required for the Classification Survey during Construction are to be submitted. If plans and documents cannot be obtained, facilities are to be given for the Surveyor to take the necessary information from the Offshore Support Vessel.

3. Sea trials tests and stability experiments

At the Classification Survey after Construction, sea trials and stability experiments are to be carried out in accordance with the requirements specified in **204. 5.** However, sea trials and stability experiments may be dispensed with provided that sufficient information based on previous tests is available and neither alteration nor repair affecting sea trials and stability experiments has been made after such previous tests.

206. Classification Survey of ships classed by other Societies

When a ship holding class with any Society which is subject to verification of compliance with QSCS(Quality System Certification Scheme) of IACS is intended for classification, plans and documents to be submitted and survey items, etc. are to be in accordance with the **Pt 1, Ch 1, 403.** of **Guidance relating to the Rules for the Classification of Steel Ships.**

Section 3 Surveys

301. General

The survey for Offshore Support Vessel are to be in accordance with the requirements specified in this Section in addition to the requirements specified in **Pt 1, Ch 2** of **Rules for the Classification of Steel Ships**.

302. Annual Survey

1. Hull, equipment and fire-extinguishing appliances

- (1) All Offshore Support Vessels (all-type)
Installations related to the specialized functional service of the Offshore Support Vessel and their supporting structures
- (2) For self-elevating Offshore Support Vessels
 - (A) Legs above the waterline
 - (B) Jack-frame and attachment to upper hull or platform
 - (C) Jacking or other elevating systems and leg guides, externally
 - (D) Plating and supporting structure in way of leg wells
- (3) At the 1st Annual Survey after construction, Column Stabilized and Self-elevating Offshore Support Vessels may be subject to examination of major structural components including non-destructive testing, as deemed necessary by the Society. If the Society deems such survey to be necessary, the extent should be agreed to by the Society and the Owner prior to the commencement of the Survey.

2. Machinery, electrical equipment and additional systems

- (1) All forms of Offshore Support Vessels
General survey for machinery and electrical equipments related the specialized functional service of the Offshore Support Vessel. Where considered necessary by the Surveyor, the performance test may be required.
- (2) For Vessels with a dynamic positioning system
General survey for elements and performance test for dynamic positioning system accordance with test procedure.
- (3) General survey for electrical equipments installed in hazardous areas. For ships over ten years of age, insulation resistance is to be carried out. However, measurements may be omitted whether the surveyor accepts that the measurement record material is maintained on board and that it is suitable.
- (4) For vessels with self-elevating system, survey on the conditions of leg guide and jacking or elevating system.

303. Intermediate Surveys

At the Intermediate Survey, in addition to all the requirements for Annual Survey, the following items are to be surveyed.

1. Hull, equipment and fire-extinguishing appliances

- (1) For self-elevating Offshore Support Vessels
For ships over 5 years of age, an internal examination and thickness measurements for at least two pre-load tanks are to be conducted. If the protective coating of those tanks is in GOOD condition, thickness measurements may be dispensed with.

2. Machinery, electrical equipment and additional systems

- (1) Survey in accordance with **302. 2** is to be carried out.
- (2) For self-elevating Offshore Support Vessels
General survey for jacking system is to be carried out. Where considered necessary by the Surveyor, overhauling of jacking system may be required.

304. Special Surveys

At the Special Survey, in addition to all the requirements for Annual Survey, the following items are to be surveyed.

1. Hull, equipment and fire-extinguishing appliances

- (1) For self-elevating Offshore Support Vessels
 - (A) All legs including chords, bracings, gussets, racks, joints, together with leg guides. Tubular or similar type legs are to be examined externally and internally, together with internal stiffeners and pinholes.
 - (B) Structure in, around and under jack-frame and leg walls. Non-destructive testing of suspect areas may be required
 - (C) Leg jacking or other elevating systems externally. Non-destructive testing of suspect areas may be required
 - (D) Leg connections to bottom mats or spud cans, including non-destructive testing of leg connections to mats or spud cans.
 - (E) Jetting piping systems or other external piping, particularly where penetrating mats or spud cans.
 - (F) Spud cans or mats. Where the spud cans or mat are partly or entirely obscured below the mud line when the Special Survey is otherwise being completed, consideration will be given to postponement of these examinations until the next move of Offshore Support Vessel.

2. Machinery, electrical equipment and additional systems

- (1) Survey in accordance with **302. 2** is to be carried out.
- (2) For self-elevating Offshore Support Vessels
General survey for jacking system is to be carried out. Where considered necessary by the Surveyor, overhauling of jacking system may be required.

305. Docking survey

1. Requirements of survey

- (1) For self-elevating Offshore Support Vessels
 - (A) External surfaces of the upper hull or platform, spud cans, mat, underwater areas of legs, together with their connections as applicable, are to be selectively cleaned to the satisfaction of the attending Surveyor and examined.
 - (B) At each Dry-docking Survey or equivalent, after Special Survey No. 2, the Surveyor is to be satisfied with the condition of the internal structure of the mat or spud cans. Leg connections to mat and spud cans are to be examined at each Dry-dock Survey or equivalent. Non-destructive testing may be required of areas considered to be critical by the Society or found to be suspect by the Surveyor.

2. Ballast spaces

In conjunction with Dry-docking Surveys (or equivalent) after Special Survey No. 1 and between subsequent Special Surveys, the following ballast spaces are to be internally examined, thickness gauged, placed in satisfactory condition as found necessary, and reported upon. If such examination reveals no visible structural defects, the examination may be limited to a verification that the corrosion control arrangements remain effective.

- (1) For self-elevating Offshore Support Vessels
Representative ballast tanks or free-flooding compartments in mat or spud cans, if accessible, and at least two representative hull pre-load tanks.

306. Surveys of propeller shaft and stern tube shaft, Etc.

Survey of Propeller Shaft and Stern Tube Shaft, Etc. is to be in accordance with **Pt 1, Ch 2, Sec 7** of **Rules for the Classification of Steel Ships**.

307. Boiler survey

Boiler Survey is to be in accordance with **Pt 1, Ch 2, Sec 8** of **Rules for the Classification of Steel Ships**. ↓

CHAPTER 3 STRUCTURES AND EQUIPMENT

Section 1 Stability

101. General

1. Intact stability are to be in accordance with the relevant requirements in **Pt 1, Ch 1, 307. of Rules for the Classification of Steel Ships** in addition to this chapter. However, for ships specifically approved by the Society, these requirements may be waived.
2. With regard to intact stability, **International Code on Intact Stability 2008 (2008 IS Code)** are to be applied in addition to the above 1.

Section 2 Hull Structures

201. Hull structure and Materials

1. Hull structure, materials, weldings and end connections are to be in accordance with the following depending upon the ship length:
 - (1) For ships which are 90 m or above, materials, hull equipment and end connections are to be according to **Pt 3 and Pt 7 of Rules for the Classification of Steel Ships**.
 - (2) For ships which are less than 90 m, materials, hull equipment, weldings and end connections are to be according to **Pt 10 of Rules for the Classification of Steel Ships**.
2. The requirements in **Pt 2, Ch 1 of Rules for the Classification of Steel Ships** are to be applied to materials used to hull structure unless specifically specified.

202. Strengthening for Heavy Cargoes

1. The requirements apply to Offshore Support Vessels intended to carry heavy deck cargo exceeding 25 kN/m² or heavy liquid cargo with specific gravity greater than 1.025.
2. **Heavy Cargoes**
 - (1) The Special Feature Notation HDC(P, Locations) will be assigned additionally to vessels designed built with strengthened for carriage of heavy deck cargoes exceeding 25 kN/m².
 - (2) The Special Feature Notation HLC(ρ , Tanks) will be assigned additionally to vessels designed built with strengthened for carriage of heavy liquid cargoes with specific gravity exceeds 1.025.

3. Submission of Data

In general, the following plans and particulars are to be submitted.

- (1) Heavy Deck Cargoes
 - (A) Structural details and arrangements of structures in way of cargo deck
 - (B) The design deck cargo loads in kN/m² and locations
 - (C) Lashing arrangement of deck cargoes
- (2) High Density Liquid Cargoes
 - (A) Tank arrangements and deep tank locations, together with their intended cargoes
 - (B) Specific gravity of highest density liquid cargoes for 100% filling of each tank
 - (C) Height of the air and overflow pipes for each tank

203. Side Fenders

1. For vessels subject to impact loads during routine operations the minimum side shell thickness is to be not less than 25% of the requirement of **Rules for the Classification of Steel Ships**, unless effective permanent fenders are provided to protect the structure .
2. Continuous longitudinal fenders are generally to be fitted on the side shell at cargo deck. The fenders are to extend from the stern to a point not less than 0.02L forward of the section at which the full deck's breadth starts decreasing; the area defined as an impact region. Additional fenders

are to also be arranged diagonally at about 45° between the foregoing fenders, as necessary, to protect the side shell from the impact.

3. Fenders may be either permanent fenders constructed of steel or having exchangeable hard wood or rubber profile inserts. Carling plates or other effective means of stiffening are to be provided so that fender loads are effectively distributed to the hull structure. Steel fenders are to be efficiently welded to the shell plating with continuous fillet welds. Alternatively the fenders may be omitted also if the side plating is at least twice the thickness that is required by 1, for a height of at least $0.01L$.
4. The upper plate may be omitted if the side shell is inclined 7° or set off 1:8 from the side's vertical (Fig 3.1). The strength of the side frames, webs and stringers in the impact region is to be increased by the factor 1.25 over the standard requirements. All side structural members in the impact region shall have end connections with brackets. Scallop welds shall not be used in connections between side frames and shell plating.

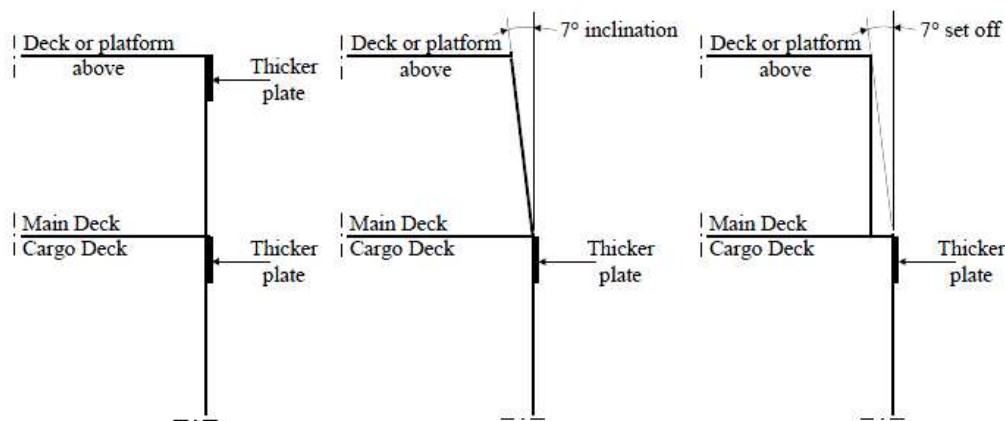

Fig 3.1 Side Impact Plates

Section 3 Hull Equipment

301. General

1. The hull equipment of Offshore Support Vessels intended to be classed or have been classed with the Society are to be in accordance with the requirements specified in this Section.
2. Hull equipment are to be in accordance with the following depending upon the ship length:
 - (1) For ships which are 90 m or above, hull equipment is to be according to **Pt 4 of Rules for the Classification of Steel Ships.**
 - (2) For ships which are less than 90 m, hull equipment is to be according to **Pt 10 of Rules for the Classification of Steel Ships.**
3. Equipment Number calculations for unconventional vessels with unique topside arrangements or operational profiles may be specially considered. Such consideration may include accounting for additional wind areas of widely separated deckhouses or superstructures in the equipment number calculations or equipment sizing based on direct calculations.
4. Cargo gear are to be in accordance with the relevant requirements in **Pt 9, Ch 2 of Rules for the Classification of Steel Ships.**

302. Offshore Mooring Chain for Station Keeping

1. Qualification of Manufacturers

Offshore mooring chain is to be manufactured by works approved in accordance with **Pt 2 of Rules for the Classification of Steel Ships** or in accordance with **Guidance for Approval of Manufacturing Process and Type Approval, Etc.**

2. Materials

Materials used for the manufacture of offshore mooring chain are to meet the requirements of **Pt 2 of Rules for the Classification of Steel Ships** or in accordance with **Guidance for Approval of Manufacturing Process and Type Approval, Etc.**

3. Design, Manufacture, Testing and Certification of Chain

Offshore mooring chain is to be designed, manufactured, tested and certified in accordance with the requirements of **Pt 2 of Rules for the Classification of Steel Ships** or in accordance with **Guidance for Approval of Manufacturing Process and Type Approval, Etc..**

Section 4 Machinery

401. General

Machinery installations of the ship are to be in accordance with the relevant requirements in **Pt 5 of Rules for the Classification of Steel Ships** in addition to this section.

402. Test

1. Before installation on board, equipment and components constituting the machinery installations are to be tested at the manufacturers in accordance with the relevant requirements in **Pt 5 of Rules for the Classification of Steel Ships**.
2. Notwithstanding the requirements in the above **1.**, for machinery installations that are used solely for the operation of the ship, other than boilers, pressure vessels belonging to Group I or II and piping systems which contain inflammable or toxic liquids, it may be substituted with tests that may be deemed appropriate by the Society.
3. The systems or the equipment essential for the safety of the ship or for the propulsion of the ship (only applicable to the ships which have the main propulsion machinery) are, after installed on board, to be subjected to performance tests.

Section 5 Electrical Installations

501. General

Electrical installations of the Offshore Support Vessel are to be in accordance with the relevant requirements in **Pt 6 of Rules for the Classification of Steel Ships** in addition to this section.

502. Test

1. Among electrical equipment used solely for the operation of the ship; fuses, circuit breakers, explosion-protected electrical equipment and cables are to be subjected to be in accordance with the requirement in **Pt 6, Ch 1, Sec 1, 103. of Rules for the Classification of Steel Ships**. However, electrical installations which do not comply with this requirement may be accepted provided that the submission of documents such as specifications, sectional assembly drawings, test reports, certificates issued by public bodies for the examination by the Society.
2. Electrical equipment used solely for the operation of the ship and not listed in the above **1.** may be in accordance with the standards deemed appropriate by the Society.
3. For electrical installations used solely for the operation of the ship, an insulation resistance test specified in **Pt 6, Ch 1, Sec 17, 1701. of Rules for the Classification of Steel Ships** and performance tests of safety devices for generators and transformers are to be carried out after installation on board.

Section 6 Fire Protection and Fire Extinguishing Systems

601. Application

1. Where Offshore support vessels, not less than 500 tons gross tonnage, are engaged in international voyage, those construction of fire protection, fire detection and fire extinction shall be complied with the requirements of **Pt 8 of Rules for the Classification of Steel Ships**. However, for Offshore support vessels less than 500 tons gross tonnage or Offshore support vessels not engaged with international voyage, they may apply to the requirements in accordance with the **Pt 8, Ch 1, 101. of Guidance relating to the Rules for the Classification of Steel Ships**. as provided separately.
2. In addition to para 1, they shall also be complied with the International Conventions of SOLAS and the National Regulations of the country in which the ships is registered.
3. Despite of para 1 and 2 for the ships not applied to the SOLAS but applied to the Ships Safety Law of Korea, those fire-fighting system shall be in accordance with the relevant requirements specified by these Laws.
4. In addition to para 1 Offshore support vessels intended to carry hazardous and noxious liquid substances in bulk are to comply with the IMO Resolution A.673(16) as amended by IMO Res.Res.MSC184(79), MSC.236(82) and Res.MEPC.158(55) requirements Guidelines for the Transport and Handling of Limited Amounts of Hazardous and Noxious Liquid Substances in Bulk on Offshore Support Vessels and the governing Administrative Regulations. ↕

CHAPTER 4 OFFSHORE SUPPLY VESSELS

Section 1 General

101. Application

1. The requirements in this chapter apply to Offshore supply vessels(hereinafter referred to as "ships") which are primarily engaged in the transport of stores, materials, equipment and/or personnel (excluding crew boats) to, from and between offshore installations.
2. The ships should comply with the requirements of this chapter in addition to **Ch 1** to **Ch 3**.

102. Scope

This chapter addresses the safety aspects related to offshore supply vessels for carrying deck cargoes, dry and liquid cargoes including flammable cargoes having a flashpoint (closed cup test) above 60°C (140°F), such as fuel oil, base oil and oil-based liquid mud.

103. Submission of Data

1. In general, in addition to the plans listed in **Ch 2, Sec 2**, the following plans and particulars are to be submitted.
 - (A) Information regarding loading arrangement of deck cargoes, weights and their centers of gravity
 - (B) Structural details and arrangements of structures in way of cargo deck
 - (C) Lashing arrangement of deck cargoes
 - (D) Details of integral liquid cargo tanks including vents and/or overflows height and location
 - (E) Details of independent liquid and/or dry cargo tanks
 - (F) Details of independent tank supports and fastening arrangements
 - (G) Piping diagrams of liquid cargo transfer systems
 - (H) Piping diagrams of dry bulk cargo transfer systems
 - (I) Ventilation diagrams of liquid cargoes
 - (J) Arrangement in dry cargo compartment
2. Where the ships are intended to carry limited amounts of hazardous and noxious liquid substances in bulk, the following materials are to be submitted in addition to the above **1**.
 - (A) General arrangements showing the locations of the following:
 - (a) Hazardous areas
 - (b) Cargo tanks with adjacent cofferdams
 - (c) Full particulars of the intended cargo or cargoes and its properties
 - (d) Cargo hatches and other openings to cargo tanks
 - (e) Doors, hatches and other openings to pump rooms and other hazardous spaces
 - (f) Ventilation ducts and openings to pump rooms and other hazardous spaces
 - (g) Doors, air locks, hatches hinged scuttles which can be opened, and other openings to non-hazardous spaces adjacent to cargo area
 - (h) Cargo pipes above the deck with loading and discharging connections
 - (i) Vent pipes for cargo tanks
 - (B) Plans for the following pumps and piping system arrangements:
 - (a) Cargo piping system including drawings showing details such as expansion elements and flange connections (pipe joints)
 - (b) Bilge piping systems in pump room, cofferdams, and pipe tunnels within the cargo area
 - (c) Cargo heating systems
 - (d) Procedures and calculations of cooling down, loading and unloading operations
 - (C) Plans for the following equipment and systems as applicable
 - (a) Pressure vacuum valves or high velocity vent valves, details and installation of safety valves and relevant calculations of their relieving capacity
 - (b) Arrangement and capacity of ventilation system in the cargo area
 - (c) Fan rotating parts and casing
 - (d) Portable ventilators
 - (e) Arrangement of inert gas supply if applicable.

- (D) Plans of electrical installations, listing the following particulars
 - (a) Drawings showing location of all electrical equipment in hazardous areas
 - (b) List of certified safe equipment
 - (c) One-line diagram for intrinsically safe circuits and data
- (E) Documents for fire protection
 - (a) Arrangement and specifications of fixed fire extinguishing systems
 - (b) Diagrams of fire and gas detection and alarm systems
- (F) Documents for the control and monitoring system
 - (a) Cargo tank level measurement system
 - (b) Cargo tank overflow protection system
 - (c) Cargo valves and pump control and monitoring system
 - (d) Inert gas control and monitoring system if applicable

Section 2 Hull Structures

201. General

Hull structures are to be in accordance with the relevant requirements in **Ch 3, Sec 2** in addition to this section.

202. Access opening

1. Access to the machinery spaces of category A of ships is to be arranged within the forecastle.
2. Any access to such machinery spaces from exposed cargo decks is to be provided with two weathertight closures.

203. Cargo deck

1. Safe havens and escape routes for personnel from the cargo deck are to be properly marked and kept clear at all times. The vessel is to be equipped with a sufficient quantity and types of lashing and securing materials for the safe operation of the vessel.
2. In cases where cargo rails are fitted onto cargo decks, the structures under the stanchions of cargo rails are to be appropriately reinforced.
3. In cases where heavy cargo is carried on deck, effective means such as steel cradles, steel or wooden dunnages, etc. are to be provided so that weight is uniformly distributed onto deck structures.
4. Pad eyes for cargo securing and/or moving are to be welded directly to the deck plating; no doublers are allowed. The pad eyes are to be adequately supported by approved deck reinforcement. Dismountable pad eyes and stanchions are to have firm attachments to the deck sockets or holdings. All pad eyes are to be permanently marked with bead welded SWL values.

204. Cargo tanks

1. Liquid cargo tanks are to be according to the following :
 - (1) In cases where hazardous and noxious liquid cargo are loaded in tanks, the quantities of liquid cargo are to be limited to 800 m³ or a volume in cubic meters equal to 40% of ship deadweight calculated at a cargo density of 1.0 t/m³. However, there are no such quantity limitations for drilling fluids (liquid mud, etc.), cargo fuel and non-noxious liquid substances.
 - (2) In cases where not bounded by bottom shell plating, fuel oil tanks, cargo pump-rooms or pump-rooms, cargo integral tanks are to be separated from other spaces by cofferdams having accessible widths of 600 mm.
 - (3) Independent tanks are to be segregated from machinery spaces, propeller shaft tunnels, if fitted, dry cargo spaces, accommodation and service spaces and from drinking water and stores for human consumption by cofferdams, void spaces, cargo pump-rooms, oil fuel tanks or other similar spaces.
2. Dry cargo tanks are to be according to the following :

- (1) In cases where cargo tanks for dry cement or mud (barite, bentonite, etc.) are fitted, these cargo tanks are to be separated from engine rooms, accommodation spaces and service spaces by watertight bulkheads and decks.
- (2) Cargo transfer piping systems are, in principle, not to be led through machinery spaces. However, in cases where such design is impractical, piping systems may pass through machinery spaces, provided that all pipe connections located within the machinery spaces are welded and any detachable connections are arranged outside of such spaces.

3. Multi-functional cargo tanks

Where cargo tanks are intended to carry dry or liquid cargoes, the following are to be applied:

- (1) With liquid cargo, the applicable requirements in **1.** are to be complied with.
 - (2) With dry cargo, the applicable requirements in **2.** are to be complied with.
4. Cargo tanks are to be located at least 760 mm measured inboard from the side of the vessel perpendicular to the centreline at the level of the summer load waterline.

205. Spill coaming

Deck areas for handling oils and oil-based liquids are to be provided with a coaming around all pumps, transfer flanges, connections and other equipment where leakage may occur. Each coaming is to be adequately sized to contain deck spills and prevent spilled cargoes from entering accommodation, machinery, control and service spaces or passing overboard. The coaming is to have a height of at least 150 mm. Where drains are provided for the coaming, closing devices for these drains are to be permanently attached.

Section 3 Cargo Piping Systems

301. Cargo Piping Systems

Cargo piping systems are in general to comply with the relevant requirements in **Pt 5, Ch 6 of Rules for the Classification of Steel Ships.**

1. Liquid Cargoes

(1) Combustible Liquid Cargoes

(A) For cargo fuel oil, base oil and oil-based liquid mud having a flashpoint exceeding 60°C, the provisions in **Pt 5, Ch 6 of Rules for the Classification of Steel Ships** are applicable for cargo tank arrangements/protection, cargo transfer piping, tank level gauging, venting and heating systems. In addition, the following are to be complied with:

- (a) Cargo pumps are to be certified in accordance with **Pt 5, Ch 6 of Rules for the Classification of Steel Ships**
- (b) An emergency means for pumping out the tanks is to be provided. For this purpose, a portable pump, which can be used safely, may be accepted.
- (c) A relief valve is to be installed in the discharge of each cargo and stripping pump. The outlet from the relief valve is to be led to the suction side of the pump. This relief valve need not be fitted in the case where centrifugal pumps are installed and the piping is designed to withstand the shut-off head of the pumps.
- (d) Remote shutdown devices for all cargo pumps and similar equipment are to be fitted and capable of being activated from a dedicated cargo control location which is manned at the time of cargo transfer and from at least one other location outside of the cargo area and at a safe distance from it.
- (e) One pressure gauge for each pump is to be located at the pump discharge. Where pumps are operated at cargo control station remote from the cargo pumps, additional pressure gauges are to be installed at the cargo control station.
- (f) Where cross-contamination either by cargoes or cargo residues causes safety hazards or marine pollution hazards, separation between cargo piping systems, is to be by means of spectacle flanges, spool pieces or equipment.

(2) Liquid Mud Cargo Tanks

Liquid mud cargo tanks are to be provided with vent pipes complying with **Pt 5, Ch 6 of Rules for the Classification of Steel Ships.** In order to prevent overpressure or under-pressure in the event of overflow into the vent pipe or clogging of the flame screen in the case of oil based mud, vents for liquid mud tanks are to also be provided with a suitable burst disc(s) rated below

the mud tank design pressure. Spare burst discs are to be carried on board so that damage burst disc can be replaced. Suitable means of gauging the mud tanks such as a tank ullage method or level indicating devices may be fitted in lieu of sounding pipe.

2. Dry Cargo Piping Systems

(1) Dry cargo transfer piping systems are, in general, not to be led through machinery spaces. However, when such design is impractical, piping systems may pass through machinery spaces, provided that all pipe connections located within the machinery space are welded and any detachable connections are arranged outside of the space. Any access door in the bulkhead is to be provided with a notice affixed to each such closing appliance to the effect that it is to be kept closed.

(2) Piping Scantlings

The minimum requirements for wall thicknesses of steel pipes in cement and dry mud system passing through machinery spaces are to be in accordance with following table.

Nom. size (mm)	25	32	40	50	65	80	90	100	125	150	200	250	300	350	400	450
Outside dia. (mm)	33.7	42.4	48.3	60.3	76.1	88.9	101.6	114.3	139.7	168.3	219.1	273	323.9	355.6	406.4	457
Wall thickness (mm)	6.3	6.3	6.3	6.3	6.3	7.1	7.1	8.0	8.0	8.8	8.8	8.8	8.8	8.8	8.8	8.8

3. Integrated Cargo Tank Piping System

For integrated cargo tanks, effective means are to be provided to prevent the use of compressed air as the primary means of discharge for combustible liquid cargoes.

302. Cargo transfer import and export system

1. Cargo Transfer Hose

- (1) Where fitted, cargo transfer hoses are to be compatible with the cargo and suitable for the cargo temperature and have a burst pressure not less than 5 times the maximum expected service pressure of the cargo transfer system.
- (2) For combustible cargoes, cargo hoses are to have electrical continuity over their entire lengths, including couplings and flanges (except shore connections) and are to be earthed for removal of electrostatic charges.
- (3) In the case of transfer operations involving pressures in excess of 5 MPa, arrangements for emergency depressurizing and disconnection of the transfer hose are to be provided.

2. Cargo Transfer Hose Emergency Disconnection

Means for emergency disconnection of the cargo hose are to be provided and capable of being activated from the vessel position control station or cargo transfer control station. The connecting coupling is to be of self-sealing type (automatic closing at disconnection).

Section 4 Machinery

401. General

Machinery installations of the ship are to be in accordance with the relevant requirements in **Pt 5 of Rules for the Classification of Steel Ships** in addition to this section.

402. Steering gear

The steering gear is to be capable of turning the rudder from 35° on one side to 30° on the other side within 20 seconds, when the vessel is running ahead at maximum service speed.

403. Engine exhaust outlets

Exhaust outlets of internal combustion engines are to be fitted with suitable spark-arresting device.



CHAPTER 5 ANCHOR HANDLING AND TOWING VESSELS

Section 1 General

101. Application

1. The requirements in this Chapter apply to Anchor handling towing vessels (hereinafter referred to as "ships" in this Chapter) equipped for the handling of anchors of offshore floating installations or equipped for towing operations.
2. The ships should comply with the requirements of this chapter in addition to **Ch 1** to **Ch 3**.

102. Submission of Data

1. In general, in addition to the plans listed in **Ch 2, Sec 2**, the following plans and particulars are to be submitted.

2. For Approval

- (1) Structural details of supporting structures in way of the anchor handling and towing winches
- (2) Structural details of stern roller, towing pins, shark jaw and their supporting structure
- (3) Details of stow racks, cargo rails, crash rails and supporting structures
- (4) Spare chain locker(s) structural details including chutes (if installed)
- (5) Structural details of A-frame and deck cranes, if certification is requested
- (6) Structural details of supporting structures of A-frames and deck cranes

3. For Information

- (1) Details on winches for anchor handling, towing and secondary winches (storage reels), as follows:
 - (A) Type, rating (braking power of the winches)
 - (B) location and layout (with foundation or foundation footprint drawing)
 - (C) Weights and centers of gravity
 - (D) Electrical and/or piping schematic diagrams of power supply and control system for the towing equipment
 - (E) Locations of control stations or human-machinery interfaces
 - (F) Arrangement and details of communication systems between anchor handling operation control stations and navigation bridge
- (2) Information regarding ropes and/or wires to be set on the above winches, as follows:
 - (A) Type, lengths, diameters minimum specified breaking strength weights
- (3) Details, ratings, location and arrangements of all the towing and/or anchor handling structures and devices in way of cargo deck, as follows:
 - (A) Steel sheet cladding on top of wooden sheathing
 - (B) Quick release device or devices (if installed)
 - (C) Shark jaws/towing pins unit or units
 - (D) Towing eye-bars (if installed)
 - (E) Anchor launch and recovery unit for deep penetrating anchors (if installed)
 - (F) A-frame (if installed), deck cranes, tugger winches and/or capstans
 - (G) Pad-eyes for securing and lashing anchors on deck
 - (H) Aft roller or rollers
- (4) Laying arrangement and weights of anchors carried as cargo
- (5) Estimated static bollard pull, together with the method of prediction. (The estimated value is to be confirmed at Trials prior to final certification)
- (6) Estimated operational pull within speed range of 0-8 knots at 1 knot intervals, together with the method of prediction (The estimated values may be based on tank test results of required power and allowable trust curves. CFD techniques may be utilized for this purpose as well The required power values are to be multiplied by the factor of 1.4 to accommodate potential power increase, necessary for station keeping in extreme environmental conditions)
- (7) Static Bollard Pull Test Procedure

Section 2 Stability

201. General

1. Intact stability during the operation of vessel are to be in accordance with the additional requirement of IS Code (2008) / PART B / Chapter 2 / 2.7 Ships engaged in anchor handling operations or IS Code (2008) / PART B / Chapter 2 / 2.8 Ships engaged in towing and escort operations, depending on the operational purpose of the vessel. (2026)
2. Stability is to be considered especially to the ships that have specially designated operations.
3. Stability calculations and corresponding information for the Master are to be submitted for review and approval.
4. The submission of evidence showing approval by an Administration of stability of the vessel for the towing operations in accordance with a recognized standard may be acceptable.

Section 3 Hull Structures

301. General

Hull structures are to be in accordance with this section in addition to relevant requirements in each chapter of **Ch 3, Sec 2**.

302. Supporting structures of anchor handling equipments

The surroundings of the supporting structures of anchor handling equipments and the part where anchors are loaded must be ensured to be sufficiently strong.

303. Suitable construction for anchor handling operation

1. Ships are to have completely clear decks with no obstacles in order to effectively handle anchors.
2. In cases where anchor handling operations are conducted using after deck stern rollers, the aft terminals nearby the stern areas for anchor handling are to be round in shape.

304. Supporting structures of towing equipment

1. In principle, towing equipment is to be located on longitudinals, beams or girders, which are parts of the deck construction.
2. In case the towing equipment cannot be located as specified in **1.** above, towing equipment is to be reinforced to the stiffener.
3. The supporting structures of towing equipment are to be such to ensure sufficient strength.
4. The design load on fittings is to take into account all acting loads.
5. The design loads for the supporting structures of towing equipment are to be not less than the breaking strength of the towline system.

305. Side Shell and Frames

For vessels subject to impact loadings during anchor handling or towing operations, it is recommended that side frames and side shell plating comply with **Ch 3, 203**.

306. Work Deck

1. Reinforcement against Impact, Wear and Tear

Plating thickness at the aft portion of the work deck is to be increased to protect the structure against heavy impact loads and wear and tear. It is recommended that minimum plating thickness in this area be not less than 25 mm. Alternative arrangements will be considered on case by case ba-

sis for re-enforcement against impact and wear and tear. Where heavy anchors and/or chains are carried on deck, suitable means for distributing their weights properly to deck structures are to be provided. The stresses in deck members are not to exceed the following **Table 5.2**.

Table 5.2 The stresses in deck members

	σ N/mm ²	τ N/mm ²
Longitudinal Beam/Girder:	124	69
Transverse Beam/Web:	140	85

307. Work Deck Protection

The aft deck areas exposed to anchor drags should not be fitted with sheathings or if present, the sheathings are to be suitably protected. In addition, any protrusion above deck such as coamings, manholes, lashing pad eyes, etc. shall be avoided.

The deck plating thickness in these areas shall be suitably increased to allow for abrasion and mechanical damage.

308. Anchors and Chains Securing Means

Pad eyes for securing and/or moving the anchors and/or chains are to be welded directly to the deck plating without doublers. The deck in way of the pad-eyes is to be adequately reinforced. Removable pad eyes are to have firm attachment to the deck sockets or holdings. All pad eyes are to be permanently marked with bead welded SWL values.

309. Arrangements for Shifting Anchors and Chains

The foundations of tugger winches and/or capstans are to be welded directly to the deck plate and with adequate reinforcement underneath.

310. Deck Openings

Access openings, including emergency exits, are to be located clear off the topline sweep area.

Section 4 Hull Equipment

401. General

1. Hull equipments are to be in accordance with the relevant requirements in **Ch 3, Sec 3** in addition to this section.
2. In cases where equipment and devices for the ship's purpose are fitted, suitable measures are to be taken so that ship safety is not impaired.

402. Protection of deck areas

Deck areas for the collection and handling of anchors and associated equipment are to be protected by wooden sheathing, etc. However, in cases where the plate thickness is increased by 2.5 mm, such protection may be omitted.

403. Safety devices

Equipment, such as winches, for anchor handling operations is to be provided with suitable safety devices so that towing wires are able to be released or cut in times of emergency.

404. Towing equipment

The towing hooks, towing bits or towing bollards fitted onto ocean tugs is to be located as low as practicable, and close to, but abaft of, the center of gravity of the ship in the expected towing condition.

Section 5 Anchor Handling/Towing Winch and Accessories

501. General (2026)

Unless otherwise specified in this section, the requirements for anchor handling/towing winch and accessories are to comply with the requirements of **Guidance for Anchor Handling Appliances**.

502. Arrangement and Control

1. Control Stations

Anchor handling and towing winches are to be capable of being operated from control stations located on the bridge and at least one additional position on deck with a clear view to the drums.

Each control station is to be equipped with suitable control elements, such as operating levers, with their functions clearly marked. Wherever practical, control levers are to be moved in the direction of the intended topline movement. The operating lever, when released, is to return into the stop position automatically and is to be capable of being secured in the stop position.

Means are to be provided for measuring the tension of the anchor handling/towing line, for display at the control stations and for initial and periodic calibration of line tension measuring instrumentation.

2. Quick Release Device

The quick release device for either the anchor handling or towing rope or wire is to be operable from the control station on the bridge or other normally manned location in direct communication with the bridge. The quick release device is to be capable of disengaging the line at any combination of expected trim and heel. It is to be operable in a black-out of the electrical power system and protected against unintentional operation. Procedures describing emergency release methods, time delays and release speed are to be specified and posted at the control stands. See the test requirements for quick release devices in **507. 1**.

3. Power Supply

Where the power supply for normal operation of the anchor handling or towing winch is taken from

the same source for propulsion, such as shaft generator, shaft power take-off (PTO), an independent (redundant) power supply with sufficient capacity for the winch operation is to be available to ensure the vessel's maneuvering capability during anchor handling or towing operations is not degraded.

503. Mechanical Design

The requirements for mechanical design of anchor handling/towing winch are to comply with the requirements of **Guidance for Anchor Handling Appliances. (2026)**

504. Towing Pins and Towing Eyes

1. Pins and Eyes

Recessed towing eyes, if provided, are to be integrated into deck structure. The recesses are to be drained directly overboard and protected when not in use by flush steel covers.

Towing pins and towing eyes are to be capable to of sustaining the breaking strength of the tow-line considering the most extreme line arrangement (see **Fig 5.3**) without exceeding the stress limits given in **502. 5**.

Stresses in structure supporting the towing pins and eyes are not to exceed the limits specified in **502. 5**.

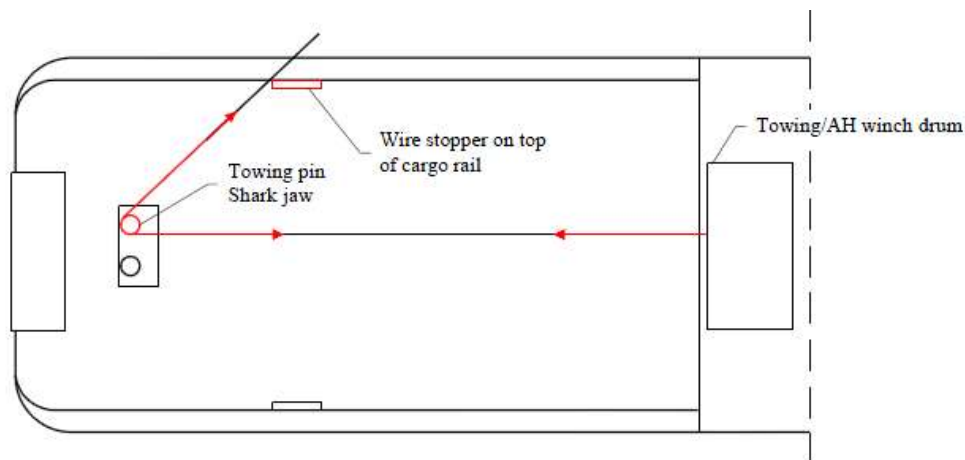

Fig 5.3 Tow Line Arrangement

505. Shark Jaws

Shark jaws and supporting structures are to be capable of sustaining the breaking strength of the anchor line or towline considering the most extreme line arrangement (see **Figure 5.3**) without exceeding the stress limits given in **502. 5**.

506. Stern Roller

The length of stern roller (or rollers) is to be kept to a minimum, and sufficient to accommodate the widest anticipated anchor to be served.

The minimum external diameter of the stern roller is to be:

$$D_{sr} = 17 d_w \text{ mm}$$

where d_w is the nominal anchor handling wire rope diameter in mm.

The roller, pin connections, foundations and supporting structure are to be designed to the breaking strength of the anchor line. The load is to be applied as shown in **Figure 5.4**. The stresses are not to exceed the following the limits given in **502. 5**.

507. A-frame or Shear Leg Type Crane

Where an A-frame or shear leg type crane is installed for anchor handling, it is to be certified for compliance with **Ch 2, Pt 9 of Rules for the Classification of Steel Ships**.

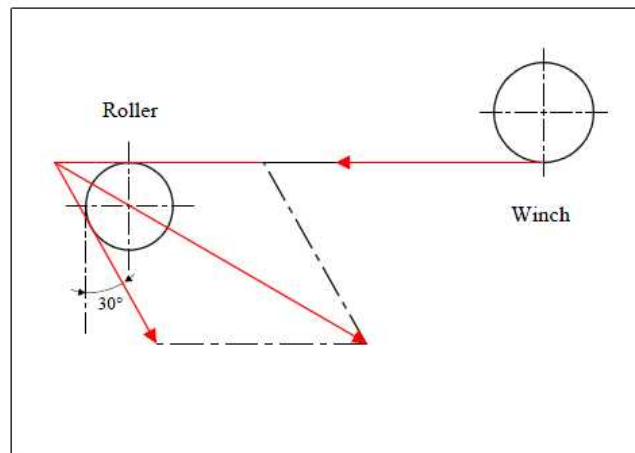

Fig 5.4 Application for Roller Load

508. Tests

1. Quick Release Device Test

The effectiveness of the quick release device is to be demonstrated during trials conducted at manufacturers' premises in presence of the Surveyor.

2. Drum Overload Clutch Test

The effectiveness of the drum overload clutches is to be demonstrated during winch acceptance trials conducted at manufacturer's premises in presence of the Surveyor.

3. Static Bollard Pull Test

The static bollard pull test procedure is to be submitted for review by the attending Surveyor in advance of the test.

The requirements for conducting a bollard pull test on vessels of duplicate design will be specially considered on a case-by-case basis.

The static bollard pull is to be measured with the vessel at the maximum continuous rpm and at or near the maximum towing depth.

The static bollard pull is the pull that is recorded over the state of equilibrium without any tendency to decline.

The depth of water under the keel in the testing area should be at least two times the vessel draft at amidships.

Section 6 Machinery

601. General

Machinery installations of the ship are to be in accordance with this section in addition to **Pt 5, Ch 3, Sec 4** of **Rules for the Classification of Steel Ships**.

602. Steering gear

The steering gear is to be capable of turning the rudder from 35° on one side to 30° on the other side within 20 seconds, when the vessel is running ahead at maximum service speed.

Section 7 Fire Protection and Fire Extinguishing Systems

701. General

Fire protection and fire extinguishing systems are to be in accordance with the relevant requirements in **Ch 3, Sec 6** in addition to this section.

702. Additional equipment for ships engaged in towing operations

Emergency exits from machinery spaces to decks are to be capable of being used even at extreme heel angles. In addition, emergency exits are to be positioned as high as possible above waterlines and positioned as near as practicable to ship centre lines. ⚓

CHAPTER 6 HEAVY LIFT VESSELS

Section 1 General

101. Application

1. The requirements in this Chapter apply to Heavy lift vessels (hereinafter referred to as "ships" in this Chapter) intended for the lifting of heavy loads in oil drilling and production operations, offshore construction and/or salvage operations, with a lifting capacity of 160 metric tons or above.
2. The vessels should comply with the requirements of this chapter in addition to **Ch 1** to **Ch 3**.

102. Submission of Data

1. In general, in addition to the plans listed in **Ch 2, Sec 2**, the following plans, calculations and particulars are to be submitted.

2. Crane Plans and Data

- (1) General arrangement, assembly plans and description of operating procedure and design service temperature
- (2) Dead, live and dynamic loads. Environmental loads including effects of wind, snow and ice. Load swing caused by non-vertical lifts. Load due to the list and/or trim of the vessel or structure.
- (3) Maximum reactions and overturning moments
- (4) Details of the principal structural parts, including crane pedestal, foundation and other crane supporting structure
- (5) Welding details and procedures
- (6) Crane capacity rating charts
- (7) Wire rope specifications
- (8) Material specifications
- (9) Details of heave compensation arrangements if applicable
- (10) Where applicable, details of swing circle assembly, arrangement of hold-down bolts, size, material, grade and pretensioning together with method used for pretensioning
- (11) Equipment for positioning during heavy weight lifting operations

3. Design Analysis

The following calculations are to be submitted.

- (1) Calculations demonstrating the adequacy of the vessel's stability during heavy weight lifting operations.
- (2) Calculations demonstrating adequacy of propulsion power required for the vessel to maintain station during heavy weight lifting operations.
- (3) Calculations demonstrating strength of the crane and supporting structures.

4. Additional Data

The following items are also to be submitted.

- (1) Plans of the electric installations of the crane
- (2) Diagrams of electrical, hydraulic and pneumatic systems and equipment for power supply and control systems for the cranes
- (3) Assembly plan showing principal dimensions of the crane and limiting positions of its movable parts
- (4) Piping diagrams for ballast and/or anti-heeling systems
- (5) Crane manual for each crane installed on board

Section 2 Stability

201. General

1. Intact stability during the operation of vessel is to be in accordance with the additional requirement of IS Code (2008) / PART B / Chapter 2 / 2.9 Ships engaged in lifting operations. (2026)

2. Stability to be considered especially to the ships that have specially designated operations.
3. The submission of evidence showing approval by an Administration of stability of the vessel for the lifting operations in accordance with a recognized standard may be accepted.
4. The dynamic load chart for each crane shall be included in the Trim and Stability Booklet and shall be posted at the crane operator's station in the clear view of the crane operator.

Section 3 Hull Structures

301. General

Hull structures are to be in accordance with this section in addition to relevant requirements in **Ch 3, Sec 2**.

302. Work Deck

1. Reinforcements

The work deck is to be strengthened for the specified design loads and non-uniform loadings are to be specified. The strong points, if required, are to be situated, as far as practicable, on crossings of bulkheads and web frames. All deck stiffeners are to be double-continuous welded.

2. Arrangement

- (1) It is recommended that fuel tanks are not located directly under the working decks, where hot works would be carried out, unless a void space, hold, store, cofferdam or water ballast tank forms a separation space between the working deck and fuel tank.
- (2) The working deck, as far as possible, is to be kept unobstructed, clear of engine room intakes and exhaust from tank vents and mooring equipment. Tank vents, mooring and deck access provisions are preferably to be grouped in way of the aft deck, boom rest and/or forecastle.

Section 4 Hull Equipment

401. General

1. Hull equipment is to be in accordance with this section in addition to relevant requirements in each chapter of **Pt 4 and Pt 10 of Rules for the Classification of Steel Ships**.
2. In cases where equipment and devices for the ship's purpose are fitted, suitable measures are to be taken so that ship safety is not impaired.

402. Supporting Structure Design Loads

1. Acceleration Loads

Ship structures supporting cranes are to be designed considering acceleration loads given below. Acceleration loads need not be combined with normal lifting operation loads of the cranes.

$$P_V = 0.102 \times [(x - L/70)] W$$

$$P_L = P_T = 0.5 W$$

where:

P_V = vertical force (kN)

P_L = longitudinal force (kN)

P_T = transverse force (kN)

L = length (m)

W = supported weight (kN)

The value of “ x ” is dependent on the location of the center of gravity of the specific equipment and is to be taken as that given in the **Table 6.2**. The value of “ x ” at intermediate locations is to be determined by interpolation. L is to be measured from AP to forward.

Table 6.2 The value of “ x ” is dependent on the location of the center of gravity of the specific equipment

AP & aft of AP	0.1L	0.2L	0.3L~0.6L	0.7L	0.8L	0.9L	FP & forward
$x = 18$	17	16	15	16	17	18	19

Alternatively, accelerations derived from other recognized standards or direct calculations, model tests considering the most severe environmental conditions the vessel is expected to encounter may be considered.

2. Lifting Loads

Maximum expected operational loads are to be applied for calculating scantlings of supporting structure.

3. Acceptable Stresses

Scantlings of structure supporting cranes are to be based on the permissible stresses given below:

Normal Stress = $0.7 \sigma_y$

Shear Stress = $0.4 \sigma_y$

Equivalent stress = $0.8 \sigma_y$

where σ_y is the specified minimum tensile yield strength or yield point.

Section 5 Machinery

501. General

Machinery installations of the ship are to be in accordance with this section in addition to **Ch 3, Sec 4**.

502. Supporting machinery and systems

1. Power System

(1) Crane with self-contained or independent power plant :

(A) Where the crane is fitted with self-contained or independent power plant with the prime mover and its auxiliary systems including the power take-off means and the starting system, the power plant is to be sized such that the minimum required hook velocity can be achieved when lifting the corresponding rated load, taking into account simultaneous operations (hoist, luff, swing) requirements, efficiencies of the power plant and the system components.

(B) Gasoline engines as prime movers are prohibited.

Engine exhausts are to be equipped with spark arrestors and all exhaust systems are to be guarded in areas where contact by personnel in the performance of their normal duties is possible.

(C) Fuel tanks fills and overflows are not to run close to exhausts. Fuel tanks are to be equipped with filler necks and caps designed to prevent fuel contamination from external sources. Removable caps, where fitted, are to be securely tethered to the filler.

(2) Cranes driven by vessel's power systems :

Where the crane is driven by vessel's power systems, either hydraulic or electric, the vessel's main power plant is to be sized with sufficient capacity to operate the crane under the load conditions defined in (1) and arranged to ensure the functioning of all safety equipment and essential services for vessel station keeping and floatability keeping are not impaired, jeopardized and degraded.

2. Heeling and ballasting systems

- (1) Where heeling systems are provided to counteract the crane's overturning moment, the systems are to be designed to ensure that the vessel is capable of withstanding the sudden loss of the hook load in each condition of loading and operation.
- (2) The free surface effects are to be considered for those tanks which are ballasted. (Refer to **203. 2. (2)**).

3. Controls and communications

- (1) Controls
 - (A) All controls used during the normal crane operating cycle are to be located within easy reach of the operator while at the operator's station.
 - (B) Control levers for boom hoist, load hoist, swing and boom telescope (when applicable) are to be returned automatically to their center (neutral) positions on release. Control operations and functions are to be clearly marked and easily visible by the operator at the operator's control station.
 - (C) As appropriate, monitoring is to be provided to indicate availability of power, air pressure, hydraulic pressure, motor running and slewing brake mechanism engagement.
 - (D) Cranes are to be provided with an overload-protection system. Motor running protection is to be provided and is to be set between 100% and 125% of motor rated current.
 - (E) Provisions are to be made for emergency stop of the crane operations by the operator at the operator's control station.
- (2) Communications

Hard-wired communications is to be provided between the crane operator's control station and the vessel's station keeping control station.

Section 6 Positioning System

601. Positioning System

1. General

Ships are to be capable of maintaining their positions safely during heavy lifting operations. The means to maintain position may be a mooring system with anchors, dynamic positioning system or a combination of both.

2. Dynamic Positioning System

Dynamic positioning systems, when used to maintain the vessel's position during heavy lifting operations, are to comply with the requirements for the class notation DPS(2) or DPS(3) in accordance with **Pt 9, Ch 4 of Rules for the Classification of Steel Ships**. ⚓

CHAPTER 7 WIND TURBINE INSTALLATION VESSELS

Section 1 General

101. Application

1. The requirements in this Chapter apply to wind turbine installation ships (hereinafter referred to as "ships" in this Chapter) which are primarily engaged in installation, maintenance and repair of off-shore wind turbines.
2. The vessels should comply with the requirements of this chapter in addition to **Ch 1 to Ch 3**.
3. For wind turbine installation units, including vessels with self-elevating, the relevant requirements in **Rules for Mobile Offshore Units** shall be applied.

Section 2 Stability

201. General

1. Intact stability are to be in accordance with this section in addition to **Ch 3, Sec 2**. However, for ships specifically approved by the Society, these requirements may be waived.
2. Stability to be considered especially to the ships that have specially designated operations.
3. Self-elevating ships are to be in accordance with **Ch 7 of Rules for Mobile Offshore Units**.
4. For ships carrying cargo on deck such as open pipes that may accumulate water inside, free surface effects are to be considered.

Section 3 Hull Structures

301. General

1. Hull structures are to be in accordance with this section in addition to relevant requirements in **Ch 3, Sec 2**.
2. Structural analysis is to be carried out in accordance with the requirements in **Ch 4, Sec 2, Sec 3 and Sec 4 of Rules for Mobile Offshore Units**.

Section 4 Hull Equipment

401. General

1. Hull equipment is to be in accordance with this section in addition to the relevant requirements in **Pt 4 and Pt 10 of Rules for the Classification of Steel Ships**.
2. In cases where equipment and devices are installed for designated operations, suitable measures are to be prepared that does not damage the safety of the ship.

402. Crane Supporting Structure

Crane supporting structure is to comply with the requirements of **Ch 6, 402**.

403. Protective coatings of tanks

For pre-load tanks on self-elevating ships, the requirements in **Ch 3, Sec 11 of Rules for Mobile Offshore Units** are to be applied.

Section 5 Machinery

501. General

Machinery installations of the ships are to be in accordance with this section in addition to **Ch 3, Sec 4**.

Section 6 Positioning Systems

601. Dynamic Positioning Systems

Dynamic positioning systems, when used to maintain the vessel's position during installation, maintenance, and repair operations, are to comply with the requirements for the class notation DPS(2) or DPS(3) in accordance with **Pt 9, Ch 4** of **Rules for the Classification of Steel Ships**. ↕

CHAPTER 8 FIRE FIGHTING VESSELS

Section 1 General

101. Application

1. The requirements in this Chapter apply to vessels intended for unrestricted service which are primarily engaged in fire fighting operation on offshore installations. The following special items related to fire fighting operations are covered under the classification:
 - (1) Vessel's fire fighting capabilities
 - (2) Vessel's stability and its ability to maintain station while fire fighting monitors are in full operation
 - (3) The degree of vessel's self-protection against external fires
2. The vessels should comply with the requirements of this chapter in addition to **Ch 1 to Ch 3**.

102. Submission of Data

1. In general, in addition to the plans listed in **Ch 2, Sec 2**, the following plans, calculations and particulars are to be submitted.
 - (1) Fire Fighting Plans and Data
 - (A) Fire-Fighting Equipment Plan, including locations of the fire pumps sea chests, fire pumps, fire mains, fire monitors, hydrants, hoses, nozzles, water-spray systems configuration, air compressor and firemen outfits.
 - (B) Technical details of fire pumps and monitors, including the capacity, range and water jet reaction of the monitors', as well as water-spray system capacity data (when fitted).
 - (C) Details of high pressure air compressor required for filling cylinders of air breathing apparatus, including purity specifications.
 - (D) Foundations for fire-fighting pumps, their prime movers and the water monitors
 - (E) Sea chest arrangements for fire-fighting systems.
 - (F) Remote and local control arrangements for water monitors.
 - (G) For FFS1 only: Water-spray piping systems, including location of nozzles, pumps and valves, with system corrosion protection and draining arrangements.
 - (H) For FFS2 or FFS3: Details of foam generators and their capacity.
 - (I) For FFS3: Foam monitor arrangements, capacity and supports, including remote and local control arrangement for the foam monitors.
 - (2) Calculations

The following calculations are to be submitted and documented.

 - (A) Calculations demonstrating the adequacy of the vessel's stability during all fire fighting operations.
 - (B) Calculations demonstrating adequacy of water monitor supports during monitor operations.
 - (C) Calculations demonstrating adequacy of propulsion power required for the vessel to maintain station during fire fighting operations.
 - (3) Additional Data

In addition to the submitted items required for classification, the following items are to be submitted.

 - (A) Data indicating that the vessel will be capable of carrying sufficient fuel oil for continuous fire fighting operation and propulsion operation with all fixed water monitors in use at the maximum required capacity for not less than:
 - (a) 24 hours: FFS1
 - (b) 96 hours: FFS2 or FFS3
 - (B) Verification that FFS3 will be capable of foam production from fixed foam monitors for at least 30 minutes of continuous operation.
 - (C) Verification that FFS2 or FFS3 will be capable of foam production from mobile generators for at least 30 minutes of continuous operation.
 - (D) Verification that the water monitor range, required by **Table 8.1**, is not less than:
 - (a) 120 meters : FFS1
 - (b) 150 meters : FFS2 or FFS3
 - (E) Verification that the vessel is in compliance with the minimum requirements of **Table 8.1**, with data on the vessel's actual design capacities also recorded.

Section 2 Stability

201. General

1. Intact stability are to be in accordance with this section in addition to **Ch 3, Sec 1**. However, for ships specifically approved by the Society, these requirements may be waived.
2. Stability to be considered especially to the ships that have specially designated operations.

202. Calculation on stability

In applying the requirements in **Ch 3, Sec 1**, the heeling lever resulting from designated operations is to be considered the one most unfavorable for stability.

203. Intact Stability Requirements for Fire Fighting Operations

1. General

The intact stability of each vessel receiving a fire fighting notation is to be evaluated for the loading conditions indicated in **Ch 3, 102**. for compliance with the intact stability criteria in **2.**, and the results are to be submitted for review.

2. Intact Stability Criteria

(1) Fire Fighting Operations

Each vessel is to have adequate stability for all loading conditions, with all fire fighting monitors operating at maximum output multiplied by a factor of 1.1 in the direction most unfavorable to the stability of the vessel. The thruster(s) are to be considered operating at the power needed to counter-act that force. For the calculation purposes, the total thruster force should be vertically located at the location of the lowest available thruster (see **Fig. 8.1**).

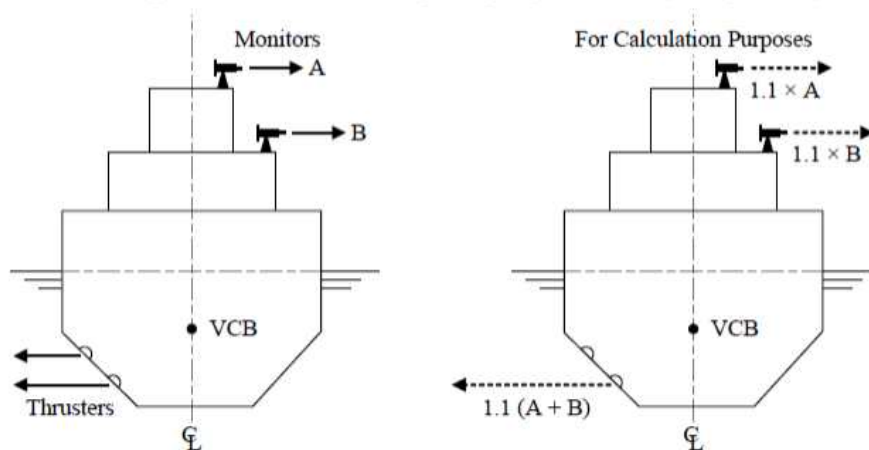

Fig. 8.1 Heeling Moments – Fire Fighting Operations

The heeling moment due to the operation of all fire fighting monitors and thrusters is to be converted to a heeling arm, and superimposed on the righting arm curve of each loading condition. The first intercept must occur before half of the freeboard is submerged. The area of the residual stability (area between the righting arm and heeling arm curves beyond the angle of the first intercept) up to an angle of heel 40° beyond the angle of the first intercept; or the angle of downflooding if this angle is less than 40° beyond the angle of the first intercept, should not be less than 0.09 meter-radians (see **Fig. 8.2**).

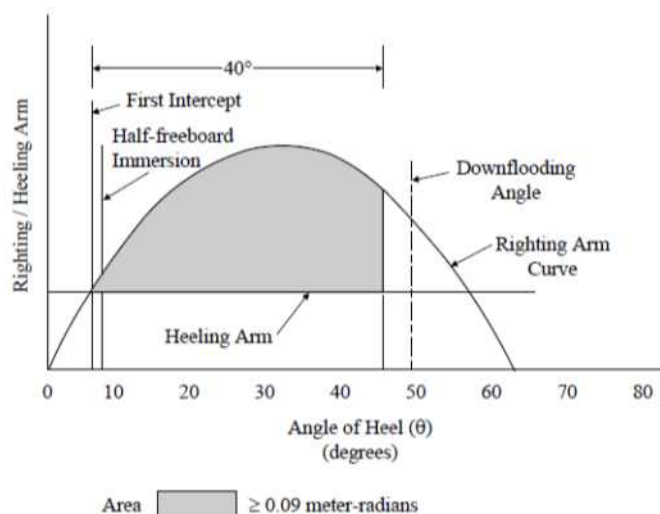

Fig. 8.2 Righting Arm and Heeling Arm Curves

3. Stability Guidance for the Master

The Master of the vessel should receive information in the Trim and Stability Booklet regarding cargo limitations, list of protected flooding openings that need to be kept closed, wind and/or wave restrictions, etc., necessary to ensure that the stability is in compliance with the criteria given in 2..

If any loading condition requires water ballast for compliance with the criteria in 2., the quantity and disposition should be stated in the guidance to the Master.

Section 3 Hull Structures

301. General

Hull structures are to be in accordance with this section in addition to the requirements of Ch 3, Sec 2.

302. Supporting structures of monitors for fire fighting

The supporting structures of the monitors for fire fighting are to be such to ensure sufficient strength to handle the reaction forces of water jets.

Section 4 Fire fighting equipment for other vessels

401. General

1. Fire fighting vessels are to be fitted with fire fighting equipment for fighting fires on other vessels and fitted with suitable equipment to ensure the safety of their own ship during fire fighting operations in accordance with Table 8.1.
2. The fuel oil tanks of fire fighting vessels are to be capable of carrying sufficient fuel oil for fire fighting operations with all fixed water monitors in use at maximum and continuous propulsion operation during the operation time specified in Table 8.1.

Table 8.1 Minimum Requirements for Fire Fighting Vessels

Class Notation	FFS1	FFS2			FFS3	
Total pump capacity ⁽¹⁾ (m ³ /h)	2,400	7,200			9,600	
Number of pumps ⁽²⁾	1	2			2	
Number of water monitors	2	2	3	4	3	4
Discharge rate per monitor (m ³ /h) ⁽³⁾	1,200	3,600	2,400	1,800	3,200	2,400
Monitor range (m)	120	150			150	
Height of water jets of monitors (m) ⁽⁴⁾	45	70			70	
Number of hose connections on each side of vessel	4	8			10	
Fixed water-spray system	1	-			-	
Mobile high expansion foam generators	-	1			1	
Fixed low expansion foam monitors	-	-			2	
Number of fire-fighters outfits	4	8			10	
Fuel oil capacity (hours)	24	96			96	
Number of search lights	2	2			2	
(Notes)						
(1) It is recommended that fire pump suction velocity generally do not exceed 2 m/sec and discharge piping to water monitors generally do not exceed 4m/sec operational velocity in order to assure adequate system capacity.						
(2) Pumps used for extinguishing fires onboard a vessel may be used for fighting fires on other vessels.						
(3) Provided that total discharge capacity of water monitors installed on FFS2 or FFS3 fire fighting vessels is equal to total pump capacity, the discharge rate per monitor may be less than that specified in the above Table. However, in all cases, the discharge rate per monitor of each monitor is to be more than 1,800 m ³ /h.						
(4) The range of water jets is to be equal or more than 70m from the nearest part of the fire fighting vessel. The height of water jets from sea level is to be at least that specified in the above.						

402. Water monitors

1. Fire fighting vessels are to be fitted with water monitors having the capacity and quantity in accordance with **Table 8.1**.
2. Water monitors are to comply with the following (1) to (6):
 - (1) Water monitors are to be located so as to allow for an unobstructed range of operation.
 - (2) The range and height of trajectory of monitor jets are to be not less than those specified in **Table 8.1** with all fixed water monitors in use simultaneously.
 - (3) Water monitors are to be capable of adequate adjustment in the vertical and horizontal directions.
 - (4) Means are to be provided for preventing monitor jets from impinging on ship structure and equipment.
 - (5) Water monitors are to be capable of being operated and maneuvered both locally and at a remote-control station. The monitor remote-control station is to have adequate overall operational visibility, including that of the water trajectory elevation, means of communication and protection from heat and water spray.

- (6) Control systems are to be suitably protected from external damage. Electrical control systems are to be provided with overload and short circuit protection. Hydraulic or pneumatic monitor control systems are to be duplicated.

403. Pumps and piping systems

1. Pumps and piping systems used for fire-fighting water monitors are to be solely for fire fighting (including operating fire hose stations) and self-protecting water spray (if applicable).

2. Pumps

- (1) Each pump is to be provided with its own dedicated, independent sea suction.
- (2) Where two or more pumps are provided, they are to have equal or near equal capacity. Minimum total pump capacity requirements are given in **Table 8.1**.
- (3) Where the fire monitor pumps are used also for water supply to water spray system and/or fire hose stations, minimum total capacity of the pumps is to be sized to ensure sufficient water supply for all connected services to be performed simultaneously.
- (4) A pump located above waterline is to be of self-priming type.
- (5) Internal combustion engines for the fire fighting pumps are to comply with **Pt 5, Ch 2 of Rules for the Classification of Steel Ships**.
- (6) Electric motors for the fire fighting pumps are to comply with **Pt 6, Ch 1 of Rules for the Classification of Steel Ships**.
- (7) The fire fighting pumps are to comply with **Pt 5, Ch 6 of Rules for the Classification of Steel Ships**.

3. Piping systems

- (1) Piping systems are to be protected from overpressure. All piping is to be suitably protected from corrosion and freezing and capable of being thoroughly drained. Suction piping lines are to be designed to avoid cavitation in the water flow. Piping arrangements are to be such that those will prevent overheating at low pump delivery rates.
- (2) Where pipes supplying water to the monitors are passing through the propulsion machinery spaces, they are to be led through the engine room casings and then externally to the super-structure and/or deckhouse, all the way to the monitors. The piping section between the pump and a deck or bulkhead's exit is to be fully welded; flange connection is only permitted at the pump or the sea water discharge valve outlet.
- (3) Piping systems used for water spray are to be independent from the system supplying water to the monitors, except that the same pumps may be used for both purposes. Where water supply to the fire hose connections is provided by the pumps for the water monitors, and/or water spray, isolation valves are to be fitted to separate the fire main system from the water monitors and/or water sprays systems and necessary pressure regulation means are to be provided so that the fire main system can be operated independently and/or simultaneously with the fire monitors and/or water spray system.

404. Sea inlets for fire fighting and valve

1. Sea chests for fire fighting operations are not to be used for services other than fire fighting operations or water spray devices.
2. The sea inlets for fire fighting and sea chests are to be arranged as low as practical to avoid clogging due to debris or ice and oil intake from the sea surface.
3. The location of sea inlets for fire fighting and sea chests is to be such that water suction is not impeded by ship motions or the water flow from propellers or thrusters.
4. All openings in ship side for at sea chests are to be fitted with strainer plates and means for cleaning in accordance with **Pt 5, Ch 6, 302. of Rules for the Classification of Steel Ships**.
5. Each sea inlet for fire fighting is to be provided with a shut off valve.
6. Fire fighting pumps, the shut off valves mentioned above, and overboard discharge valves are to be operable from the same locations.
7. The starting of fire fighting pumps in cases where shut off valves are closed is to be prevented by providing either interlock systems or by audible and visual alarms.

405. Fire hoses and nozzles

1. Fire fighting vessels are to be provided with hose connections on the weather deck of each side of the vessel, in accordance with **Table 8.1**.
2. Hoses are to be not less than 38 mm or more than 65 mm in diameter, and are to be at least 15 m in length.
3. Each nozzle is to be capable of producing a jet and spray.
4. A water jet flow of at least 12 m is to be provided.

406. Fixed water spray system (FFS1)

1. General requirements

- (1) FFS1 is to be provided with a permanently installed water-spray system.
- (2) The water-spray system is to provide protection for all exposed decks and external vertical areas of the hull, superstructure and deckhouses, including water monitor foundations and equipment associated with the water monitors.
- (3) All the water-spray system piping, valves and nozzles are to be suitably protected from damage during fire fighting operations.

2. System Capacity

- (1) The minimum capacity of the water-spray system is to be in accordance with **Table 8.2** for the total protected area.
- (2) Necessary visibility of water-spray operations from the navigating bridge and from the monitor's remote-control station is to be provided.
- (3) For vessels which are fitted with a dynamic positioning system which is at least capable of automatically maintaining the position and heading of the vessel under specified maximum environmental conditions having an independent centralized manual position control with automatic heading control, the minimum capacity of the water spray system may be based on the maximum areas which may be exposed to the fire, provided the water-spray system is divided into zones so that those areas which are not exposed to radiant heat can be isolated.
- (4) The controls are to be located in a dedicated, readily accessible and safe location

Table 8.2 Minimum Requirements for Water Capacity

Location to be Protected	Minimum Water Capacity L / minute / m ²
Un-insulated steel (vertical areas)	10
Un-insulated steel (horizontal areas)	5
Wood sheathed steel decks	10
Steel boundaries internally insulated to Class A-60 ⁽¹⁾	5
(Notes)	
(1) Applicable for outside vertical areas only. No requirements for exposed deck insulated by A-60.	

3. Spray System Pumps

- (1) Spray system pumping capacity is to be sufficient to insure a supply pressure and volume for adequate operation of the water-spray system.
- (2) If the water monitor pumps are used, they are to be provided with sufficient capacity to provide pressure and volume for both the water monitors and the water-spray systems.

4. Protections

- (1) Water-spray systems are to be protected from corrosion.
- (2) Drainage arrangements are to be provided to protect against freezing water damage.
- (3) Deck scuppers and freeing ports are to be provided to assure efficient drainage of water from deck surfaces when the water-spray system is in operation.

407. Foam generator (FFS2 and FFS3)

1. FFS2 and FFS3 are to have mobile, high expansion foam generators for fire-fighting of minimum capacity 100 m³/min.
2. Total volume of foam forming liquid carried onboard the vessel is to provide of at least 30 minutes foam production.
3. On FFS3, this foam generator requirement is in addition to the fixed foam monitor system requirement in **508**.

408. Foam Monitor System (FFS3)**1. General**

- (1) FFS3 is to have two fixed, low expansion foam monitors in addition to the required water monitors.
- (2) Each foam monitor is to have a minimum capacity of 5000 L/min with a foam expansion ratio of 15 to 1 and is to be capable for a height of throw of 50 m above the sea level, with both foam monitors in simultaneous operation at maximum foam output.
- (3) The foam concentration tank is to have a minimum capacity for 30 minutes foam production at an assumed admixture of 5 percent.

2. Arrangements

- (1) The foam monitor system is to be of a fixed design with separate foam concentration tank, foam mixing unit and pipelines to the foam monitors.
- (2) The water supply may be taken from the water monitor pumps. Means to reduce supply water pressure may be required to assure correct water pressure for maximum foam generation.

3. Control

- (1) The fixed foam monitors are to have both local (manual) and remote control.
- (2) The remote control of the foam monitors is to be located at the remote-control station for the water monitors and is to include remote control of water and foam concentrate.

409. Fireman's outfit

1. FFS1, FFS2 and FFS3 are to have the minimum number of fireman's outfits as indicated in **Table 8.1**.
2. Each fire-fighter's outfits is to be comply with **Pt 8, Ch 8, 901**. of **Rules for the Classification of Steel Ships**.
3. At least one set of fully charged spare air bottles is to be provided for each apparatus for fireman's outfit.
4. An air compressor or equivalent capable of fully recharging all breathing air bottles for the fireman's outfit with air free from contamination within 30 minutes is to be provided.
5. Information on the fireman's outfit is to be displayed near the storage area for the user.

410. Searchlights

1. Two searchlights are to be provided on all fire fighting vessels to facilitate effective fire fighting operations at night.
2. The searchlights are to be capable of providing an effective horizontal and vertical range of coverage and are to provide an illumination to a distance of 250 m in clear air at a minimum level of illumination of 50 lux within an area of not less than 11 m diameter.

Section 5 Machinery

501. General

Machinery installations of the ship are to be in accordance with this section in addition to the requirements of **Ch 3, Sec 4**.

502. Propulsion machinery

1. Propulsion machinery is to have sufficient power to secure stable maneuverability during fire fighting operations.
2. Propulsion machinery is to be able to maintain ship position in still water as well as the capacity of water monitors during fire fighting operations at not more than 80% of the propulsion force in any direction.

3. Control systems

Control systems are to be provided with the following functions to prevent complete loss of power due to power overloads:

- (1) Alarm devices which give alarms in cases where propulsion power exceeds 80 % during fire fighting operations.
- (2) Means which reduce the speed

Section 6 Fire Protection and Fire Extinguishing Systems

601. General

Fire protection, means of escape and fire extinguishing systems are to be in accordance with this section in addition to the requirements in **Ch 3, Sec 6**.

602. Fire protection

1. FFS1

All exterior boundaries of FFS1, including exposed bulkheads, exposed decks and the hull above the lightest operating waterline are to be of steel structures and protected by a fixed water-spray system, in accordance with **406**.

2. FFS2 and FFS3

- (1) Generally, all exterior boundaries of FFS2 and FFS3 are to be of steel but need not be protected by a fixed water-spray system nor internally insulated.
- (2) Special consideration will be given to the boundaries to be constructed of materials other than steel. Details of the materials and of the protection which may be required to be provided are to be submitted to Society for review.

603. Windows

On FFS2 and FFS3, which are not provided with water-spray systems, steel deadlights or shutters are to be provided on all windows and port lights, except in the navigation bridge.

Section 7 Positioning Systems

701. Thrusters and Propulsion Machinery

The vessel is to have thrusters and propulsion machinery of sufficient power for maneuverability during fire fighting operations and as follows.

702. Positioning

Thrusters and the vessel's propulsion machinery are to be able to maintain the vessel on position in still water during all combinations of operation and capacity of the water monitors, at not more than 80 percent of available propulsion force in any direction.

703. Control

Adequate operating control systems are to be provided for fire-fighting operations which are to include an alarm condition at 80 percent of available propulsion power and automatic reduction of power action at 100 percent available propulsion power to prevent sudden or complete loss of power due to power overload. Calculations are to be submitted verifying that an equilibrium state between the reaction force from the water monitors and the force from the vessel's propulsion machinery and its side thrusters (at the most unfavorable combination) is at or less than 80 percent of the available propulsion power. This is to confirm that the vessel would maintain its position without setting off the 80 percent alarm condition. ⚡

CHAPTER 9 OIL SPILL RECOVERY VESSELS

Section 1 General

101. Application

1. The requirements of this Chapter apply to the operation of offshore support vessels (hereinafter called "ships") that may be employed to recover oil from a spill. As such, these vessels may be equipped to handle, store and transport recovered oil.
2. The ships should comply with the requirements of this chapter in addition to **Ch 1** to **Ch 3**.
3. Requirements additional to those given in this Chapter may be imposed by the National Administration with whom the vessel is registered or by the Administration within whose territorial jurisdiction the vessel is intended to operate.

102. Submission of Plans

In addition to the plans required to be submitted by **Ch 2, 204**, the following additional plans, documents, and calculations are to be submitted in the same manner.

1. Plans

- (1) Plans and particulars of recovered oil tanks indicating access.
- (2) Structural and general arrangement plans indicating the location, support and fastening arrangements of oil recovery and handling equipment.
- (3) Plan showing arrangement of structural fire protection and location, controls and particulars of fire extinguishing systems and fire safety equipment.
- (4) Diagrammatic plans of piping systems for handling recovered oil. These plans are to be accompanied by lists of material giving size, wall thickness, maximum working pressure and material of all pipes and the type, size, pressure rating and material of valves and fittings.
- (5) Diagrammatic plans of recovered oil tank venting arrangements including the position of vent outlets.
- (6) Diagrammatic plans of recovered oil heating systems, if installed.
- (7) Plans showing hazardous locations and electrical equipment in these locations together with a listing of equipment manufacturers and model numbers and evidence of certification for explosion-proof, intrinsically-safe and pressurized equipment. Also, wiring plans, installation instructions and certification agency restrictions for intrinsically-safe systems.
- (8) Plans showing electrical power supply, protection and cabling for oil recovery equipment.
- (9) Plans showing hazardous areas and spaces including the arrangement of ventilating systems for all hazardous areas along with complete particulars of the ventilating system such as capacities of fans, number of complete changes of air per hour, air flows, areas subject to positive or negative pressure, and location and direction of opening of self-closing doors.

2. Documents

- (1) Detailed specifications for gas detection/measuring equipment.
- (2) Detailed Operations and Procedures Manual

3. Calculations

- (1) Load analysis of structural support in way of deck equipment during oil recovery operations in at least moderate sea conditions.
- (2) Electrical load analysis considering the use of oil recovery equipment during oil recovery operations.
- (3) Stability analysis considering all relevant operational conditions including ballasting.

103. Operating Manual

An approved Operating Manual detailing operational and maintenance procedures, equipment and capacity data, and particulars on operation of the vessel during oil recovery mode of operations is to be placed aboard the vessel for the guidance of the operating personnel. The vessel is to be operated during oil recovery mode of operation in accordance with this approved Operating Manual.

The Operating Manual is, in general, to give information regarding the following:

- (1) Arrangement and equipment
 - (A) Tank arrangement with venting systems
 - (B) Recovered oil transfer system
 - (C) Gas measuring instruments
 - (D) Gas detection systems, if installed
 - (E) List of oil response equipment and supplies
- (2) Oil Recovery Operations and Procedures verifying that all equipment installed in hazardous locations and/or transferred onboard are certified for use in gas-hazardous atmosphere
 - (A) Instructions regarding the use of non-certified electrical equipment
 - (B) Changing-over to low sea suctions for all sea water cooling pumps and fire pumps
 - (C) Hook-up and equipment deployment
 - (D) Tank filling procedures
 - (E) Heating of recovered oil, if applicable
 - (F) Discharging of recovered oil
 - (G) List of spaces and equipment that may be required to be secured
 - (H) List of deadlights that may be required to be secured
 - (I) Recovered oil piping and venting configuration instructions
 - (J) Space specific ventilation requirements
 - (K) Storage location and use of portable gas detection/measuring instruments
 - (L) Installation of spill coamings
- (3) Safety Instructions
 - (A) Fire fighting
 - (B) Guidelines regarding safe distance from an oil spill source including specifying conditions when to withdraw the vessel from oil recovery operations.
 - (C) Gas measurements during operation (on open deck and in spaces where gas might accumulate)
 - (D) Actions to be taken if gases are detected in enclosed spaces (cleaning, ventilation, emptying of adjacent tanks, etc.)
 - (E) Precautions against overfilling of tanks
- (4) Cleaning and gas-freeing of tanks and pipes
- (5) Stability in all relevant operational conditions including ballasting guidance.

Section 2 Definitions

201. Definitions of Terms

The following definitions of terms are to be understood (in the absence of other specifications) where they appear in this Chapter.

1. Hazardous Areas

Hazardous areas are all those areas where a flammable atmosphere may be expected to exist continuously or intermittently. Hazardous areas are subdivided into Zones 0, 1, 2, defined as follows:

- (1) Zone 0 : A zone in which ignitable concentrations of flammable gases or vapors are continuously present or present for long periods.
- (2) Zone 1 : A zone in which ignitable concentrations of flammable gases or vapors are likely to occur in normal operating conditions.
- (3) Zone 2 : A zone in which ignitable concentrations of flammable gases or vapors are not likely to occur in normal operating conditions, and if it occurs, it will exist only for a short time.

Section 3 Hull Structures

301. General

1. Hull structures are to be in accordance with this section in addition to the requirements of **Ch 3 Sec 2**.
2. Oil spill recovery vessels are to be constructed of steel.
3. The vessel is to be provided with safe working areas on deck for handling of hoses and oil recovery equipment during oil recovery operations. Working areas are to be provided with adequate lighting, hand-rails and gratings or other non-slip surfaces.
4. The vessel is to be provided with storage tanks for recovered oil. Tanks used for the storage of liquid mud may be used for the storage of recovered oil. The coating used in recovered oil storage tanks is to be of an oil and dispersion resistant type.
5. Bridge visibility is to easily permit the monitoring of the oil recovery operations on deck and in the water. Alternatively, special consideration will be given to systems providing equivalent bridge visibility.

Section 4 Hull Equipment

401. General

Hull equipment is to be in accordance with this section in addition to the requirements of **Ch 3, Sec 3**.

402. Lifting Appliances on Deck and Supports for Oil Recovery Equipment

Lifting appliances such as masts and cranes intended to be used during oil recovery operations are to be designed and constructed to the applicable requirements of **Pt 9, Ch 2 of Rules for the Classification of Steel Ships** in addition to the following:

- (1) The dynamic loads due to the vessel's motions are to be considered.
- (2) The scantlings of the supporting structures for lifting appliances are to comply with **Ch 6, 402**.
- (3) The calculations for the strength of the supporting structures of lifting appliances for oil recovery equipment may be carried out assuming the oil recovery operations are being conducted in moderate sea conditions.

Section 5 Tank Arrangement

501. Tank Arrangement

1. Location and Separation of Recovered Oil Tanks

(1) General

Oil spill recovery vessels are not required to have double hulls.

Where double bottoms are fitted to comply with any applicable regulation or other purposes, they are to be fitted between the peaks or as near thereto as practicable. The double bottom is not to be lower at any point than a plane parallel with the keel line and situated at a height not less than $B/20$ measured from the keel line, but in no case less than 0.76 m and need not exceed 2 m.

Where wing tanks are located at a distance inboard of the molded line of the side shell plating, this distance is to be nowhere less than 600 mm to permit easy access for inspection.

The minimum size of the access openings to the double bottoms and wing tanks, where fitted, is to be at least 380 mm × 585 mm and circular openings to be at least 457 mm.

(2) Separation of Recovered Oil Tanks

Tanks for recovered oil are not to be located below machinery spaces, service spaces, control stations and accommodation spaces.

Tanks for recovered oil may be located forward or aft of machinery spaces, service spaces, con-

trol stations and accommodation spaces. Recovered oil tanks are to be isolated from such spaces by means of a cofferdam. For the purposes of this requirement, void spaces, pump rooms, fuel oil tanks and compartments arranged solely for ballast may be considered cofferdams. For easy access, the minimum width of the cofferdam is not to be less than 600 mm.

Where it is impractical to meet the cofferdam requirement in above, considerations may be granted in the case of other machinery spaces. A cofferdam will not be required between the recovered oil tanks and other machinery spaces, provided the following items are met:

- (a) The bulkhead plating/tank side wall is to be continuous through all joining structures to the top of the tank. Full penetration welding is required at the top of the tank and the contiguous boundaries.
- (b) The common tank bulkhead/tank side wall is to be readily accessible under normal conditions for inspection.
- (c) The machinery space adjacent to the recovered oil tanks is to be provided with forced power ventilation system as follows:
 - (i) At least twenty (20) air changes per hour, based on the gross volume of the space
 - (ii) The system is to be operated at all times whenever recovered oil is carried in the tanks. This is to be clearly indicated in the Operating Manual.
 - (iii) The ventilation system is to be designed and arranged with redundancy such that at least 100% ventilation system is still available after a single failure in any part of the system.
 - (iv) Fitted with alarms to indicate ventilation failure
 - (v) Fitted with non-sparking fans either with the uncertified motor outside of the ventilation duct or with a certified explosion proof motor located within the duct
- (d) No penetrations that create a source of hazardous vapor or oil release are allowed through the common tank boundary bulkhead. Sources of hazardous vapor or oil include any openings, screwed and flanged pipe connections, valves, pumps, stuffing boxes, etc. All welded pipe connections are not considered sources of hazardous vapor or oil.
- (e) The tanks are to be hydrostatically tested at the Special Surveys.
- (f) The common tank bulkhead is to be gauged at Intermediate and Special Surveys.

2. Location of Recovered Oil Tank Openings

Openings from recovered oil storage tanks including sounding pipes, vents and hatches are not to be located in enclosed spaces. For the purposes of this requirement, spaces open on one side only are to be considered enclosed.

3. Penetration of Recovered Oil Tanks

Electrical cables are not to pass through recovered oil tanks unless enclosed within an oil tight trunk or equivalent. Piping not related to the transfer of recovered oil is not to pass through recovered oil tanks unless the piping is made of steel, Extra-Heavy and of all welded construction, without valves, flanges, fittings or take-down joints.

Section 6 Machinery and Electrical Installations in Hazardous Areas

601. Classification of Areas of Hazardous Areas

The following hazardous areas are those which normally apply to offshore support vessels engaged in oil recovery operations.

1. Hazardous Areas Zone 0 include : (2019)

- (1) The internal space of recovered oil tanks and pipes including the venting arrangements of the recovered oil tanks.

2. Hazardous Areas Zone 1 include :

- (1) Cofferdams and voids adjacent to recovered oil tanks, containing recovered oil pipe flanges, valves, or other sources of release. (2019)

- (2) Recovered oil pump rooms, spaces in which oil contaminated equipment for handling the recovered oil is located, and oil handling areas.
- (3) Enclosed or semi-enclosed spaces in which recovered oil pipe flanges, valves, or other sources of release are located.
- (4) Areas on the open deck within a 3 meter radius of any recovered oil tank opening, recovered oil tank vent, recovered oil pipe flange or valve.
- (5) Areas on the open deck within a 3 meter radius of any entrance or ventilation opening to any hazardous area zone 1 space.
- (6) Areas on the open deck within a 3 meter radius of any oil recovery equipment. Equipment includes but is not limited to skimmers, containment booms and reels, and separators.
- (7) Areas on open deck within spillage coaming surrounding oil recovery manifold valves and 3 m beyond the coaming up to a height of 2.4 m above the deck.

3. Hazardous Areas Zone 2 include :

- (1) Except machinery spaces that are isolated from recovered oil tanks by means of a cofferdam, enclosed spaces immediately adjacent to recovered oil tanks in any direction, not containing recovered oil pipe flanges, valves, or other sources of release.
- (2) Enclosed or semi-enclosed spaces having a direct access or opening to any hazardous area.
- (3) Air lock spaces between Zone 1 and non-hazardous space
- (4) Areas on the open deck within 1.5 m radius of any entrance or ventilation opening to any hazardous area zone 2 space excluding tanks adjacent to recovered oil tanks not containing recovered oil pipe flanges, valves, or other sources of release.

602. Machinery Installations in Hazardous Areas

1. Mechanical equipment is to be limited to that necessary for operational purposes.
2. Mechanical equipment and machinery in hazardous areas are to be so constructed and installed as to reduce the risk of ignition from sparking due to the formation of static electricity or friction between moving parts and from high temperatures of exposed parts due to exhausts or other emissions.
3. Internal combustion engines are not to be installed in the hazardous areas. The installation of internal combustion machinery may be permitted in Zone 1 and Zone 2 hazardous areas, provided that the Society is satisfied that sufficient precautions have been taken against the risk of dangerous ignition.
4. Fired boilers are not to be installed in hazardous areas.
5. Exhaust outlets of internal combustion engines are to be fitted with suitable spark arresting devices.
6. Air intakes are to be located not less than 3 m from the hazardous areas.
7. Exhaust outlets and outlets of vent pipes from crankcases of internal combustion engines and exhaust outlets of boilers are to be located outside the hazardous areas.
8. Oil recovery apparatus is to be constructed so as to ensure the safety to the operator and so as not to ignite the explosive gas.
9. At least one piece of gas detection equipment is to be provided in order to detect gases in enclosed non-hazardous spaces and in other spaces deemed necessary by the Society in case those spaces contain source of ignition. One piece of portable gas detection equipment is to be provided where the fixed gas detection equipment is only provided on board.
10. Exhaust pipes or any other pipes with surface temperatures exceeding 220°C are not to pass through gas hazardous areas
11. Piping not related to the transfer of recovered oil is not to pass through recovered oil tanks unless the piping is made of steel ,extra-heavy and of all welded construction, without valves, flanges, fittings or take-down joints.

12. Where machinery spaces are located forward of recovered oil storage tanks, propulsion shafting is not to be led through the tanks and is to be effectively grounded.

603. Electrical equipment in hazardous areas

1. Electrical equipment in hazardous areas is to be in accordance with **Pt 6, Ch 1, Sec 5** and **Sec 9** of **Rules for the Classification of Steel Ships**.
2. Electrical cables are not to pass through recovered oil tanks unless enclosed within an oil tight trunk or equivalent.
3. Electrical equipment located in hazardous locations that is not intended to be used during oil recovery operations and does not meet **1.** may be permitted, provided the location is considered hazardous only during oil recovery operations and the arrangements meet the following requirements.
 - (1) The electrical equipment is to be considered nonessential and is not to be used during oil recovery operations.
 - (2) A detailed list of such equipment in each hazardous area is to be submitted for review.
 - (3) The electrical equipment as submitted for review in item (2) above is to be arranged so that it cannot be energized when any oil recovery equipment is energized. Once deenergized, specific action by the crew is to be required to reenergize the equipment. Instruction plates are to be placed at the respective switches.
 - (4) The oil recovery Operating Manual is to clearly indicate the following :
 - (A) The systems that are deenergized during oil recovery operations and the procedure to be followed.
 - (B) The instructions and procedures to be followed relative to the cleaning and gas freeing of the oil recovery tanks in order to reset the electrical equipment to its original state after oil recovery operations are completed.

Section 7 Fire Protection and Fire Extinguishing Systems

701. General

Fire protection and fire extinguishing systems are to be in accordance with the requirements in **Ch 3, Sec 6**.

702. Structural Fire Protection

1. Fire Integrity of Exterior Bulkheads

For superstructures and deck houses enclosing accommodation and machinery spaces, the exterior bulkheads facing the cargo area and side bulkheads within a distance of 3 m from the end bulkhead facing the cargo area are to be of steel construction and insulated, up to the underside of the deck of the navigation bridge, to "A-60" standard as defined in Chapter II-2/Regulation 3 of the International Convention for the Safety of Life at Sea (SOLAS) 1974, as amended with the exception of the following:

- (1) Insulation to "A-0" standard is acceptable provided the bulkheads are protected by a fixed water-spray system with a minimum water capacity of 10 liters/minute/m².
- (2) Insulation to "A-0" standard is acceptable without a water-spray system provided the bulkheads are at least one deck above the cargo area and are at least 10 meters measured horizontally away from a vertical plane of the recovered oil tanks and sources of oil or vapor release (such as tank vents, valves, flanges, and fittings).

Access doors and closing appliances for openings are to meet the same requirements as the bulkhead.

2. Openings in Exterior Bulkheads

Accesses and ventilation openings for spaces containing essential equipment are to be available for use at all times. However, accesses and openings not needed during oil recovery operations may be provided the arrangements comply with the following:

- (1) Access doors, air inlets and openings to accommodation spaces, service spaces, control stations and machinery spaces may face the cargo area and/or be located within the above limits provided they are located at least one deck above the cargo area and are at least 3 meters measured horizontally away from a vertical plane of the recovered oil tanks and sources of oil or vapor release.
- (2) Access doors are self-closing gas-tight, secured (i.e., kept closed), and fitted with signs indicating that the doors are to remain closed during oil recovery operations. In addition, the doors are to have a fire rating equivalent to the boundary in which they are installed.
- (3) All access and means of escape otherwise required by the Guidance are met without the use of the secured access doors.
- (4) Portlights and windows fitted in locations other than the navigation bridge may face the cargo area and/or be located within the limits provided they are of the fixed (non-opening) type. They are to be fitted with deadlights constructed of steel or other equivalent material, which must be secured during oil recovery operations.
- (5) Bolted plates for the removal of machinery may face the cargo area and/or be fitted within the limits.

703. Spill Coaming

Oil handling areas and equipment on deck are to be provided with a coaming around all pumps, transfer flanges and other connections where leakage may be expected. Each coaming is to be adequately sized to contain deck spills and prevent recovered oil from entering accommodation, machinery, control and service spaces or passing overboard. The coaming is to have a height of at least 150 mm.

Where drains are provided for the coaming, closing devices for these drains are to be permanently attached.

Spill coamings may be of the removable type.

704. Ventilation systems installed in hazardous areas

1. Recovered oil pump rooms and enclosed spaces in which oil recovering apparatus is located are to be provided with an exhaust-type mechanical ventilation system with an air change rate not less than 20 times per hour. Inlets of the ventilation system are to be located as high as practicable in non-hazardous areas. However, the ventilation system for small recovered oil pump rooms which contain no source of ignition may be dispensed with the requirements in this paragraph, subject to the approval of the Society.
2. Driving motors for fans of the ventilation systems for hazardous areas are to be installed outside ventilation ducts. Fans and casings are to be designed so as not to emit sparks due to contact of moving parts or formation of static electricity. ⚡

CHAPTER 10 CABLE LAYING VESSEL (2026)

Section 1 General

101. Application

1. The requirements in this Chapter apply to Cable Laying Vessels (Cable Layer) (hereinafter referred to as "ships" in this Chapter) for submarine cable laying, maintenance and repair service
2. The ships should comply with the requirements of this chapter in addition to **Ch 1 to Ch 3**.

102. Definition

1. **Cable Laying Equipment** means equipment used for laying or recovering cables at a specified tension and speed, including Linear Cable Engines, Cable Tensioners, Carousels and Storage Winches
2. **Linear Cable Engine (LCE)** means equipment that grips a cable by means of multiple rollers and is used to lay or recover the cable in a linear direction at a specified tension and speed.
3. **Cable Tensioner** means equipment used to control the tensile force applied to a cable so as to maintain a constant tension and to prevent excessive tension or slackening of the cable.
4. **Carousel** means equipment used during marine operations for storing flexible pipelines, umbilicals, cables and other products during transportation and installation, in which the product is stored in horizontal or vertical layers around a central vertical core.
5. **Reel** means equipment used for storing flexible pipes, umbilicals, risers and other offshore products during transportation and installation.
6. **Traction Winch** means a winch usually consisting of two drums, the operating principle of which is based on the friction build-up between the drums and the wire rope, and which is used to generate and control the tension required for laying or recovering cables or wire ropes.
7. **Storage Winch** means a winch arranged to operate in combination with a traction winch, the purpose of which is to store the wire rope and to provide a constant hold-back force to the traction winch. The storage winch has relatively low load capability compared with the traction winch.

Section 2 Stability

201. General

1. Intact stability are to be in accordance with **Ch 3, Sec 1**. However, for ships specifically approved by the Society, these requirements may be waived.

Section 3 Hull Structures

301. General

1. Hull structures are to be in accordance with this section in addition to relevant requirements in **Ch 3, Sec 2**.

302. Work Deck

1. The work deck is to withstand uniform deck loadings specified by the designer and provided with an allowance for corrosion and wear.
2. The work deck is to be away from engine room intakes and exhausts to protect personnel from

harmful gases, excessive temperature and noise. In addition, obstructions from tank vents are to be avoided.

303. Deck plating for helicopter landing

1. Where decks for Helicopter taking off and landing are provided, it shall comply with the relevant requirements of **Pt 3, Ch 5 of Rules for the Classification of Steel Ships.**

Section 4 Hull Equipment

401. General

1. Hull equipment is to be in accordance with this section in addition to relevant requirements in **Ch 3, Sec 3.**
2. In cases where equipment and devices are installed for designated operations, suitable measures are to be prepared that does not damage the safety of the ship.

402. Cranes

1. General

If a crane is installed, it shall comply with the relevant requirements of **Pt 9, Ch 2 of Rules for the Classification of Steel Ships.**

2. Crane Supporting Structure

Crane supporting structure is to comply with the requirements of **Ch 6, 402.**

Section 5 Machinery

501. General

1. The machinery installations of cable laying vessels are to comply with the relevant requirements of Chapter 3, Section 4, in addition to those specified in this Section.
2. The requirements of this Section apply to all mechanical, hydraulic and electrical drive systems used during cable laying, recovery and storage operations..
3. Equipment and systems(including components) used solely for cable laying operations may be exempted from classification, provided that they are designed and manufactured in accordance with standards recognized by the Society, such as international standards or other equivalent specifications.
4. The standards applied to the design of such equipment are to be clearly indicated and the relevant documentation is to be submitted for review.

502. Main Propulsion and Thrusters

1. Sufficient propulsion power and thrusters are to be provided so as to ensure safe maneuvering and maintaining of the vessel's operational capability during cable laying and transit operations.
2. Control systems for propulsion and auxiliary thrusters are to be provided with means for automatic shutdown and alarm in the event of overload or power failure, and redundant control and power supply arrangements are to be ensured so that loss of thrust does not occur during operations.

503. Drive Systems for Cable Laying Equipment

1. Drive systems for cable laying equipment (such as carousel, reel, storage winch and linear cable en-

gine) may be powered from the vessel's main power supply or an independent power source, and are to have adequate capacity for the intended operational loads.

2. Hydraulic pumps, electric motors and control valves are to be capable of maintaining cable tension and speed within the required limits, and are to be provided with emergency stop, manual stop and automatic stop functions.
3. Exhaust and cooling arrangements for such drive systems are to be located so as not to interfere with ventilation of cable storage areas or the cable control room.
4. Upon completion of installation, sea trials are to be carried out for the cable laying equipment, and the trials are to include verification of normal operation, control performance, emergency stopping functions and the performance of safety devices.
5. During sea trials of the cable laying equipment, due care is to be taken regarding rotating components, hot surfaces and other associated hazards, and the consequences of failure of such equipment or their systems are to be duly considered.
6. Records of the sea trials for the cable laying equipment, including major test items and results, are to be submitted to the Society for confirmation by the attending Surveyor.

504. Safety and Control Systems

1. The principal operating parameters of the cable laying equipment, such as cable tension, speed and torque, are to be capable of being monitored from the control room, and automatic shutdown or alarm functions are to be activated in the event of abnormal conditions.
2. Remote and automatic control functions of the equipment are to be arranged so as to be operable from the navigation bridge or cable control room, and redundant arrangements of control and communication circuits are to be provided.
3. Cable laying equipment are to be provided with Emergency Stop and Emergency Release devices, and are to be arranged so as to enable safe stopping even in the event of electrical power failure or loss of hydraulic pressure.

505. Survey

1. General.

- (1) Surveys and attendance are to comply with the relevant requirements of **Ch 2, Sec.2** and **Sec.3**
- (2) Where considered necessary by the Surveyor, or upon the request of the Owner, the scope of survey may be specially considered so that additional inspections or witnessing of tests may be carried out.

2. Annual Survey

During the annual survey, cable laying equipment is to be examined with due consideration to the following items, in addition to the applicable survey requirements:

- (1) General external condition of the equipment, including damage, deformation, wear and corrosion.
- (2) Condition of supporting structures.
- (3) Excessive clearances and lubrication condition of main rotating parts, hinged connections and joints.
- (4) Condition of wire ropes, including end attachments, with respect to wear and corrosion.
- (5) General external condition of hydraulic and electrical installations.
- (6) Functional testing of control, safety and emergency stop systems.

3. Special Survey

During the special survey, cable laying equipment is to be examined in accordance with the requirements of the annual survey, and in addition, the following items are to be confirmed by surveyor.

- (1) Open-up inspection of major pins, bolts and connections, or verification of maintenance and inspection records, as applicable.
- (2) Where deemed necessary, functional testing or load testing taking into account the design loads.
- (3) Comprehensive functional testing of control, protection and safety systems.

Section 6 Positioning System

601. Positioning System

1. General

Ships are to be capable of maintaining their positions safely during cable laying, maintenance and repair service. The means to maintain position may be a mooring system with anchors, dynamic positioning system or a combination of both.

2. Dynamic Positioning System

Dynamic positioning systems, when used to maintain the vessel's position during heavy lifting operations, are to comply with the requirements for the class notation DPS(2) or DPS(3) in accordance with **Pt 9, Ch 4 of Rules for the Classification of Steel Ships**.

602. Supporting Structure for Cable laying Equipment

Supporting structure of cable laying equipment is to be in accordance with the requirements of **Ch 6, 402**.

Section 7 Fire Protection and Fire Fighting

701. General

1. Fire protection and fire fighting requirements for cable laying vessels are to comply with **Ch 3, Sec 6 of this Guidance**.
2. For open decks or working areas where cable laying equipment is installed, fire fighting arrangements suitable for the risk level and characteristics of the area may be provided in order to prevent the spread of fire in the event of fire occurrence.
3. For areas where cable laying equipment is installed, the installation criteria for fire fighting systems are to be determined taking into account the relevant requirements of the FSS Code and **Pt 8 of the Rules for the Classification of Steel Ships**. ↴

CHAPTER 11 CREW TRANSFER VESSEL

Section 1 General

1. The requirements in this Chapter apply to Crew transfer vessels (CTV) (hereinafter referred to as "ships" in this Chapter) of not more than 500 gross tonnage, carrying no more than 12 passengers, and primarily engaged in transporting industrial personnel (IP).
2. The ships should comply with the requirements of this chapter in addition to **Ch 1** to **Ch 3**.
3. For high speed and/or light crafts, the **Rules for the Classification of High Speed and Light Craft** are to be applied.

Section 2 Stability

201. General

1. Intact stability are to be in accordance with this section in addition to **Ch 3, Sec 1**. However, for ships specifically approved by the Society, these requirements may be waived.
2. Stability to be considered especially to the ships that have specially designated operations.

Section 3 Hull Structures

301. General

1. Hull structures are to be in accordance with this section in addition to relevant requirements in **Ch 3, Sec 2**.

Section 4 Hull Equipment

401. General

1. Hull equipment is to be in accordance with this section in addition to relevant requirements in **Ch 3, Sec 3**.
2. In cases where equipment and devices are installed for designated operations, suitable measures are to be prepared that does not damage the safety of the ship.

Section 5 Safe Transfer of Personnel

Safe transfer personnel is to be in accordance with relevant requirements in **Annex 1, 102. 2**. However, for ships specifically approved by the Society or the relevant flag state, these requirements may be waived. ↓

Annex 1 SHIPS CARRYING INDUSTRIAL PERSONNEL (IP)

101. General

1. Application

- (1) Matters not specified in this annex shall be governed by the IP Code.
- (2) IP Code requirements may be regarded as complying with the requirements of this annex.

102. Goal and functional requirements

1. Industrial personnel(IP)(IP Code 2.1)

(1) Goal

The goal of this paragraph is to provide:

- (A) for safe operations during the carriage of industrial personnel; and
- (B) that industrial personnel are medically fit and familiar with the hazards associated with the operational environment including the risks associated with personnel transfer operations.

(2) Functional requirements

In order to achieve the goal set out in (1) above, the following functional requirements are embodied in the regulations in **103**:

Means shall be provided to ensure that industrial personnel:

- (A) are medically fit;
- (B) are able to communicate with the ship's crew;
- (C) have received appropriate safety training;
- (D) have received onboard ship-specific safety familiarization; and
- (E) have received onboard familiarization with the ship's transfer arrangements and equipment.

2. Safe transfer of personnel(IP Code 2.2)

(1) Goal

The goal of this paragraph is to provide for the safety of all persons involved in personnel transfer, including safe and suitable means of transfer and the capability of safely carrying out the operations connected to personnel transfer.

(2) Functional requirements

In order to achieve the goal set out in (1) above, the following functional requirements are embodied in the regulations in **103**:

- (A) Means shall be provided to avoid injuries during personnel transfer.
- (B) Arrangements for personnel transfer shall be:
 - (a) designed, constructed and maintained to withstand the loads they are subjected to;
 - (b) designed and engineered to fail to a safe condition in the event of a loss or reduction in their associated functionality; and
 - (c) capable of safely returning persons in transfer to a safe location after loss of power.
- (C) Means for position keeping shall be provided and arranged in a manner that prevents accidents during transfer of personnel and is suitable for the mode of operation and interactions with other ships or offshore facilities.
- (D) Means shall be provided to ensure that the information on the number of industrial personnel on board and their identity is kept updated to assist in ensuring that the actual number of persons on board is known at all times.

3. Subdivision and stability(IP Code 2.3)

(1) Goal

The goal of this paragraph is to provide for adequate stability of the ship, in both the intact and damaged conditions, taking into consideration the total number of persons on board.

(2) Functional requirement

In order to achieve the goal set out in (1) above, the ship shall be designed with weathertight and watertight boundaries providing for an adequate stability standard, in both the intact and damaged conditions, taking into account the total number of persons on board. This functional requirement is embodied in the regulations in **104**. and **105**.

4. Machinery installations(IP Code 2.4)

(1) Goal

The goal of this paragraph is to provide for machinery installations capable of delivering the re-

quired functionality to ensure safe navigation and safe carriage of persons on board both during normal operation and in any emergency situation, taking into account the total number of persons on board.

(2) Functional requirements

In order to achieve the goal set out in (1) above, the following functional requirements are embodied in the regulations in **104.** and **105.;**

- (A) where the capacity needed to ensure the required functionality of any machinery system is dependent on the number of persons on board (e.g. bilge pumping systems), necessary additional capacity shall be provided;
- (B) steering gear systems shall be capable of maintaining steerage after any incident affecting machinery installations; and
- (C) essential systems shall have the necessary redundancy or isolation, or a combination thereof, in order to ensure the capability of safely accommodating persons on board after any incident affecting machinery installations, taking into account the number of persons on board.

5. Electrical installations(IP Code 2.5)

(1) Goal

The goal of this paragraph is to provide for:

- (A) emergency sources of power capable of delivering the required functionality of essential systems in emergency situations, taking into account the total number of persons on board; and
- (B) protection of all persons on board from electrical hazards.

(2) Functional requirements

In order to achieve the goal set out in (1) above, the following functional requirements are embodied in the regulations in **104.** and **105.;**

- (A) emergency power supply to essential systems shall have the necessary redundancy or isolation, or a combination thereof, to ensure the capability of safely accommodating persons on board after damage, taking into account the number of persons on board and the time for
- (B) precautions against shock, fire and other hazards of electrical origin shall be provided.

6. Periodically unattended machinery spaces(IP Code 2.6)

(1) Goal

The goal of this paragraph is to ensure that, if and when a machinery space is periodically unattended, this does not impair the safety of the ship or the persons on board.

(2) Functional requirements

In order to achieve the goal set out in (1) above, the following functional requirements are embodied in the regulations in **104.** and **105.;**

- (A) periodically unattended machinery spaces shall provide safe operations, taking into account the number of persons on board; and
- (B) a periodically unattended machinery space shall be equipped with additional controls, monitoring and alarm systems to provide safe operation, taking into account the number of persons on board, in order to achieve a safety equivalent to that of a normally attended machinery space.

7. Fire safety(IP Code 2.7)

(1) Goal

The goal of this paragraph is to fulfil the fire safety objectives of SOLAS or the basic fire safety principles of the HSC Code, taking into account the number of persons on board.

(2) Functional requirement

In order to achieve the goal set out in (1) above, the means to fulfil the fire safety functional requirements of SOLAS or the basic fire safety principles of the HSC Code, taking into account the number of persons on board, are embodied in the regulations in **104.** and **105.**

8. Life-saving appliances and arrangements(IP Code 2.8)

(1) Goal

The goal of this paragraph is to provide for appropriate and sufficient means to ensure safe abandonment of the ship and recovery of persons.

(2) Functional requirements

In order to achieve the goal set out in (1) above, the following functional requirements are embodied in the regulations in **104.** and **105.;**

- (A) the capacity of the survival craft shall be sufficient to accommodate all persons on board;
- (B) appropriate and sufficient personal life-saving appliances shall be available for all persons on

- board;
- (C) sufficient space for assembling and mustering must be ensured;
- (D) onboard communication and alarm systems shall be provided to ensure emergency communication to all persons on board; and
- (E) means shall be provided to ensure the safe recovery of persons.

9. Dangerous goods(IP Code 2.9)

(1) Goal

The goal of this paragraph is to provide for the safe carriage of industrial personnel while transporting and handling dangerous goods on ships certified in accordance with this Annex, taking into consideration the total number of persons on board.

(2) Functional requirement

In order to achieve the goal set out in (1) above, any hazard caused by the transportation and handling of dangerous goods shall be taken into account and the risk to all persons on board shall be minimized, having regard to the nature of the dangerous goods. This functional requirement is embodied in the regulations in **104.** and **105.**

103. Regulations

1. Industrial personnel(IP)(IP Code 3.1)

- (1) In order to meet the functional requirements set out in **102. 1, (2), (A)**, all industrial personnel shall be at least 16 years of age and documentary evidence shall be made available to the master that they are physically and medically fit to fulfil all their requirements in this regulation, based on a standard acceptable to the Administration.
- (2) In order to meet the functional requirements set out in **102. 1, (2), (B)**, all industrial personnel shall demonstrate adequate knowledge of the working language on board in order to be able to communicate effectively and understand any instructions given by the ship's crew.
- (3) In order to meet the functional requirements set out in **102. 1, (2), (C)**, all industrial personnel shall, prior to boarding the ship, receive training or instruction with respect to:
 - (A) personal survival that includes:
 - (a) knowledge of emergency situations that may occur on board a ship;
 - (b) the use of personal life-saving equipment;
 - (c) safely entering the water from a height, and survival in the water; and
 - (d) boarding a survival craft from the ship and water while wearing a lifejacket;
 - (B) fire safety that includes knowledge of the types of fire hazards on board ships and precautionary measures to be taken to prevent a fire; and
 - (C) personal safety and social responsibilities that include:
 - (a) understanding the authority of the master or their representative on board;
 - (b) complying with instructions provided by the shipboard personnel; and
 - (c) understanding safety information, symbols, signs and alarm signals found on board ships.
- (4) Notwithstanding the requirements of (3), suitably qualified industrial personnel based on a standard acceptable to the Administration may be considered to meet the functional requirements set out in **102. 1, (2), (C)**
- (5) No industrial personnel shall be carried on board the ship unless the master has been provided with documentation confirming that such personnel have received the training or instructions required by this regulation.
- (6) In order to meet the functional requirement set out in **102. 1, (2), (D)**, all industrial personnel shall, prior to leaving port or immediately after boarding, receive onboard ship-specific safety familiarization that includes:
 - (A) the layout of the ship;
 - (B) the location of personal life-saving appliances, muster and embarkation stations, emergency escape routes and first aid stations;
 - (C) the safety information, symbols, signs and alarms on board; and
 - (D) action to be taken in the event of an alarm sounding or the declaration of an emergency.
- (7) In order to meet the functional requirement set out in **102. 1, (2), (E)**, all industrial personnel shall, prior to being transferred, receive familiarization in the ship's procedures, arrangements and any additional safety measures or equipment for the transfer of personnel to other ships and/or offshore facilities.

2. Safe transfer(IP Code 3.2)

- (1) In order to meet the functional requirement in **102. 2, (2), (A)**, the following applies:
 - (A) Personnel transfer appliances and arrangements shall be kept clean, properly maintained and regularly inspected to ensure that they are safe to use.
 - (B) The rigging and use of the personnel transfer arrangements shall be supervised by a responsible officer and operated by properly trained personnel. Safety procedures shall be established and followed by personnel engaged in rigging and operating any mechanical equipment.
 - (C) Means of communication shall be provided between the supervising responsible officer and the navigation bridge.
 - (D) All personnel transfer arrangements shall be permanently marked to enable identification of each appliance for the purposes of survey, inspection and record-keeping. A record of use and maintenance shall be kept on board the ship.
 - (E) Prior to commencing personnel transfer operations, the personnel transfer arrangements shall be checked to ensure they are functioning properly.
 - (F) Means shall be provided to ensure safe and unobstructed passage for industrial personnel between the personnel transfer arrangements and where they are being transported or accommodated on board.
 - (G) Lighting capable of being supplied by the emergency source of power shall be provided to illuminate the personnel transfer arrangements, the water below the transfer arrangements and the passage specified in (F) above.
 - (H) The deck area for personnel transfer shall be designated and free from obstructions.
 - (I) A job safety analysis shall be carried out when planning, and before executing, personnel transfer at sea. The analysis shall take into account environmental conditions, as well as operational and equipment limitations.
 - (J) When planning personnel transfer, the guidance developed by the Organization (MSC-MEPC.7/Circ.10) or other relevant guidance acceptable to the Administration should be taken into account.
- (2) In order to meet the functional requirement in **102. 2, (2), (B)**, personnel transfer arrangements shall be designed, constructed, tested and installed in accordance with standards acceptable to the Administration or requirements of a classification society which is recognized by the Administration in accordance with the provisions of SOLAS regulation XI-1/1.
- (3) In addition, the following applies:
 - (A) The design of the personnel transfer arrangements shall be suitable for the arrangement on the ship.
 - (B) An analysis shall be performed in order to evaluate failures in IP transfer arrangements and all its associated systems which might impair the availability of the transfer arrangements and/or endanger the safety of the persons involved. Appropriate analysis may be QFA or FMEA and their associated reports.
 - (a) consider the effects of failure in all the equipment and systems due to single failure, fire in any space or flooding of any watertight compartment that could affect the availability of the transfer arrangements; and
 - (b) provide solutions to ensure the availability of the IP transfer arrangements and the safety of all persons involved upon such failures identified in (a).
 - (C) Where a single failure results in failure of more than one component in a system (common cause failure), all the resulting failures shall be considered together. Where the occurrence of a failure leads directly to further failures, all those failures shall be considered together.
- (4) In order to meet the functional requirement in **102. 2, (2), (C)**, the manoeuvrability of the ship together with the expected need for the ship to keep position over time shall be evaluated, to ensure the correct use of position-keeping equipment.
- (5) In order to meet the functional requirement in **102. 2, (2), (D)**, procedures shall be in place to ensure correct information on the number and identity of personnel on board at all times.

104. Additional regulations for ships certified in accordance with SOLAS Chapter 1

1. General(IP Code 4.1)

- (1) Unless expressly provided otherwise in this part, ships carrying industrial personnel shall meet the SOLAS requirements for cargo ships and the applicable regulations in this part.
- (2) Ships complying with (1) in addition to the applicable regulations in this part are considered to meet the goals and functional requirements in **102. 3** to **102. 9**.

2. Subdivision and stability(IP Code 4.2)

- (1) In order to meet the functional requirement set out in **102. 3**, (2), the following applies:
- (A) Where the ship is certified to carry more than 240 persons on board, it shall meet the requirements of SOLAS regulation II-1/5 as though the ship is a passenger ship and the industrial personnel are counted as passengers. However, SOLAS regulation II-1/5.5 is not applicable.
- (B) Subdivision and damage stability shall be in accordance with SOLAS chapter II-1, where the ship is considered a passenger ship and industrial personnel are counted as passengers, with the value R as follows:
- (a) where the ship is certified to carry more than 240 persons, the value R is assigned as R;
- (b) where the ship is certified to carry not more than 60 persons, the value R is assigned as 0.8R; or
- (c) for more than 60 persons, but not more than 240 persons, the value R shall be determined by linear interpolation between the values given in sub-paragraphs (a) and (b) above.

$$R = 1 - \frac{5,000}{L_s + 2.5N + 15,225}$$

Where:

N = number of persons for whom lifeboats are provided

L_s = number of persons (including officers and crew) the ship is permitted to carry in excess of 240

- (C) Where the conditions of service are such that compliance with 2. (1), (B) above on the basis of L_s is impracticable and where the Administration considers that a suitably reduced degree of hazard exists, a lesser value of N may be taken but in no case less than 240.
- (D) For ships to which 2. (1), (B), (a) above applies, the requirements of **SOLAS regulations II-1/8 and II-1/8-1** and of **SOLAS chapter II-1 parts B-2, B-3 and B-4** shall be applied as though the ship is a passenger ship and the industrial personnel are passengers. However, **SOLAS regulations II-1/14 and II-1/18** are not applicable.
- (E) For ships to which 2. (1), (B), (b) and 2. (1), (B), (c) above apply, except as provided in paragraph 2.1.6 below, the provisions of **SOLAS chapter II-1, parts B-2, B-3 and B-4** shall apply as though the ship is a cargo ship and the industrial personnel are crew. However, the requirements of **SOLAS regulations II-1/8 and II-1/8-1** need not be applied and **SOLAS regulations II-1/14 and II-1/18** are not applicable.
- (F) All ships certified in accordance with this regulation shall comply with **SOLAS regulations II-1/9, II-1/13, II-1/19, II-1/20 and II-1/21** as though the ship is a passenger ship.

3. Machinery installations(IP Code 4.3)

- (1) In order to meet the functional requirement set out in **102. 4**, (2), (A), the ship shall comply with **SOLAS regulation II-1/35-1** as though the ship is a passenger ship.
- (2) In order to meet the functional requirement set out in **102. 4**, (2), (B), where the ship is certified to carry more than 240 persons on board, it shall comply with the requirements of **SOLAS regulation II-1/29** as though the ship is a passenger ship.

4. Electrical installations(IP Code 4.4)

- (1) In order to meet the functional requirement set out in **102. 5**, (2), (A), the following applies:
- (A) for installations in ships of more than 50 m in length carrying not more than 60 persons on board, the requirements in **SOLAS regulation II-1/42.2.6.1** shall apply in addition to the requirements in **SOLAS regulation II-1/42** shall apply.
- (2) In order to meet the functional requirement set out in **102. 5**, (2), (B), for installations on ships carrying more than 60 persons on board, **SOLAS regulation II-1/45.12** shall apply.

5. Periodically unattended machinery spaces(IP Code 4.5)

In order to meet the functional requirements set out in **102. 6, (2)**, ships carrying more than 240 persons on board shall be considered as passenger ships in relation to SOLAS chapter II-1, part E.

6. Fire safety(IP Code 4.6)

- (1) In order to meet the functional requirements set out in **102. 7, (2)** and **102. 4, (2), (C)**, the following applies:
- (A) where the ship is certified to carry more than 240 persons on board, the requirements of **SOLAS chapter II-2** for passenger ships carrying more than 36 passengers shall apply; and
 - (B) where the ship is certified to carry more than 60, but not more than 240 persons on board, the requirements of **SOLAS chapter II-2** for passenger ships carrying not more than 36 passengers apply, except that **SOLAS regulations II-2/21** and **22** need not apply.

7. Life-saving appliances and arrangements(IP Code 4.7)

- (1) In order to meet the functional requirement set out in **102. 8, (2)**, the following applies:
- (A) for ships carrying more than 60 persons on board, the requirements of **SOLAS chapter III** for passenger ships engaged on international voyages, which are not short international voyages, shall apply;
 - (B) regardless of the number of the persons on board, **SOLAS regulations III/2** and **III/19.2.3** are not applicable;
 - (C) where the term "passenger" is used in **SOLAS chapter III**, it shall be read to mean industrial personnel as prescribed in **SOLAS regulation XV/2.3**; and
 - (D) notwithstanding (C) above, the required number of infant or child lifejackets shall be calculated solely based on the number of passengers on board.

8. Dangerous goods(IP Code 4.8)

- (1) General
Industrial personnel may only bring dangerous goods on board for the purpose of their role off the ship and with the prior consent of the master of the ship. These dangerous goods shall be considered as cargo and shall be transported in accordance with part A of **SOLAS chapter VII**.
- (2) Carriage of dangerous goods in packaged form
In order to meet the functional requirements in **102. 9, (2)**:
- (A) for ships certified to carry more than 240 persons on board, **SOLAS regulation II-2/19.3.6.2** for passenger ships carrying more than 36 passengers shall apply; and
 - (B) for the purpose of the requirements of the IMDG Code, ships certified to carry more than 240 persons on board shall be considered as passenger ships and those certified to carry 240 or fewer persons on board shall be considered as cargo ships.
- (3) Carriage of dangerous goods in solid form in bulk
In order to meet the functional requirements in **102. 9, (2)**:
- (A) for ships certified to carry more than 240 persons on board, **SOLAS regulation II-2/19.3.6.2** for passenger ships carrying more than 36 passengers shall apply; and
 - (B) for the purpose of the requirements of the IMSBC Code, industrial personnel shall be considered as personnel in the context of personnel protection.
- (4) Carriage of dangerous liquid chemicals, liquefied gases and oil
(A) In order to meet the functional requirements in **102. 9, (2)**, when simultaneously carrying dangerous liquid chemicals and/or liquefied gases as cargo in bulk and industrial personnel, the ship shall either be certified in accordance with their requirements of parts B or C of **SOLAS chapter VII** or meet and be certified in accordance with a standard not inferior to that developed by the Organization.

In addition:

- (a) carriage of toxic products, low-flashpoint products or acids shall not be allowed when the total number of persons on board exceeds 60;
- (b) for the purpose of carrying industrial personnel, the areas and spaces on ships where industrial personnel are not permitted to enter shall be clearly marked;
- (c) the arrangements for personnel transfer shall be located outside the cargo area;
- (d) the access to the arrangements for personnel transfer shall, as far as practicable, be located outside the cargo area; and
- (e) embarkation or personnel transfer and loading or unloading of cargo shall not take place simultaneously.

- (B) In order to meet the functional requirements in **102. 9, (2)**, when simultaneously carrying oil as cargo, as defined in Annex I of MARPOL, and industrial personnel, the additional requirements in (A) above shall apply.
- (C) low-flashpoint products mean:
 - (a) noxious liquid substances with a flashpoint not exceeding 60°C;
 - (b) oil with a flashpoint not exceeding 60°C; and
 - (c) liquefied gases which require flammable vapour detection in accordance with chapter 19 of the IGC Code;
- (D) toxic products mean:
 - (a) dangerous chemicals to which special requirement 15.12 of the IBC Code applies; and
 - (b) liquefied gases which require toxic vapour detection in accordance with chapter 19 of the IGC Code; and
- (E) acids mean dangerous chemicals to which special requirement 15.11 of the IBC Code applies.
- (F) In order to meet the functional requirements in **102. 9, (2)** when carrying liquefied gases in bulk, for the purpose of the requirements of the IGC Code, industrial personnel shall be considered as personnel in the context of training and personnel protection.

105. Additional regulations for craft certified in accordance with SOLAS Chapter X

1. General(IP Code 5.1)

- (1) High-speed cargo craft certified in accordance with **SOLAS chapter X** shall not carry more than 60 persons on board.
- (2) Unless expressly provided otherwise in this part, high-speed craft carrying not more than 60 persons on board shall meet the requirements for cargo craft in the **HSC Code** and the applicable regulations in this part.
- (3) Craft complying with (2) above in addition to the applicable regulations in this part are considered to meet the goals and functional requirements in **102. 3 to 102. 9**.
- (4) The carriage of IP on high-speed craft is not considered as transit voyage, as specified in **1.9.1.1 of the HSC Code**, and a permit to operate is required.
- (5) Where the term "passenger" is used in applicable requirements in the HSC Code, it shall be read to mean persons on board other than crew.

2. Subdivision and stability(IP Code 5.2)

In order to meet the functional requirement set out in **102. 3, (2)**, the following applies:

- (1) **Chapter 2, part B, except 2.13.2 and 2.14, of the HSC Code** shall apply in lieu of **chapter 2, part C of the HSC Code**.
- (2) When applying the provisions of **chapter 2 of the HSC Code**, the expression "passenger" shall be read as "persons on board other than crew". In addition, the mass of each such person shall be assumed to be 90 kg instead of 75 kg.

3. Machinery installations(IP Code 5.3)

- (1) In order to meet the functional requirement set out in **102. 4, (2)**, provisions in **chapter 10, part B of the HSC Code** shall apply as applicable to category A passenger craft in lieu of **chapter 10, part C of the HSC Code**.

4. Electrical installations(IP Code 5.4)

In order to meet the functional requirement set out in **102. 5, (2)**, **12.7.10 of the HSC Code** shall apply.

5. Periodically unattended machinery spaces(IP Code 5.5)–No provisions

6. Fire safety(IP Code 5.6)–No provisions

7. Life-saving appliances and arrangements(IP Code 5.7)

In order to meet the functional requirement set out in **102. 8, (2)**, the following applies:

- (1) **4.2.3 of the HSC Code** shall apply;
- (2) **8.4.3 of the HSC Code** shall apply - the expression "passenger spaces" shall be read as "IP area"; and
- (3) the required number of infant or child lifejackets shall be calculated solely based on the number of passengers on board.

8. Dangerous goods(IP Code 5.8)

(1) General

Industrial personnel may only bring dangerous goods on board for the purpose of their role off the craft and with the prior consent of the master of the craft. These dangerous goods shall be considered as cargo and shall be transported in accordance with **chapter 7, part D of the HSC Code**.

(2) In order to meet the functional requirements in **102. 9, (2)**:

- (A) for the purpose of carrying IP, the areas and spaces on craft where IP are not permitted to enter shall be clearly marked;
- (B) the arrangement for personnel transfer shall be located outside the cargo area;
- (C) the access to the arrangements for personnel transfer shall, as far as practicable, be located outside the cargo area; and
- (D) embarkation or personnel transfer and loading or unloading of cargo shall not take place simultaneously.

**GUIDANCE FOR OSV
(Offshore Support Vessels)**

Published by

KR

36, Myeongji ocean city 9-ro, Gangseo-gu,
Busan, Republic of Korea

TEL : +82 70 8799 7114

FAX : +82 70 8799 8999

Website : <http://www.krs.co.kr>

Copyright© 2026, KR

Reproduction of this Guidance in whole or in parts is
prohibited without permission of the publisher.